

SW-406-6

SOLAR WINGS Ltd.  
OPERATORS HANDBOOK  
PEGASUS FLASH 2.  
ROTAX 462 LIQUID COOLED ENGINE

SOLAR WINGS LIMITED  
56 GEORGE LANE  
MARLBOROUGH  
WILTSHIRE  
SN8 4BY

SOLAR WINGS Ltd.

PEGASUS FLASH 2. OPERATORS HANDBOOK.

ROTAX 462. LIQUID COOLED ENGINE.

CONTENTS

SECTION.		PAGE No.
1.	GENERAL.	1.
1.2	Undercarriage.	1.
1.3	Power Unit.	1.
1.4	Fuel.	1.
1.5	Engine Controls.	1.
1.6	Flight Controls and Flight Characteristics.	2.
1.7	Stall Characteristics.	2.
1.8	General Flight Control.	2.
1.9	Take Off.	3.
1.10	Landing.	3.
1.11	Ground Handling.	3.
2.	Rigging.	4.
3.	De-Rigging.	6.
4.	Inspection.	7.
4.2	Transportation.	9.
5.	Post Flight Checks.	9.
5.1	Wing.	9.
5.1	Trike.	9.
6.	Engine Starting.	9.
7.	Airworthiness Operating Limitations.	10.
8.	Maintenance.	10.
9.	Airframe Life and Maintenance Schedule.	13.
9.1	Recommended Inspection Schedules.	13.
10.	Repair.	15.
10.1	Wing.	15.
10.2	Trike.	15.
11.	Tuning the Wing.	15.
11.1	Wing Trim.	15.
11.2	Pitch Trim.	16.
11.3	Leech Lines.	16.
11.4	Maintenance and Repair.	16.
11.4	Warning.	16.
12.	General Information Sheets.	17/18/19.
13.	Flash 2. Wing G/A.	20.
14.	Leech Line Settings.	21.
APPENDIX 1	Foot Brake - Description and Operation	

SOLAR WINGS Ltd.

OPERATORS HANDBOOK

PEGASUS FLASH 2.

ROTAX 462. LIQUID COOLED ENGINE.

1. GENERAL.

1.1. The Pegasus Flash 2. in its basic form is a simple load-carrying module. It allows the pilots to carry out a wide variety of operations. The Pegasus Flash 2. can also be used as a safe and reliable training machine. The frame of the trike is a monopole structure of aluminium tubes with a wire-braced tricycle undercarriage. The tandem seats are suspended in a seat frame.

UNDERCARRIAGE.

1.2. The rear wheels are fitted to stub axles which may be replaced easily and cheaply. The main axle itself is a wire-braced aluminium strut. The steering foot pedals (right foot pushed forward gives left turn and vice versa for the left foot) operate the nosewheel steering incorporating trailing-link spring suspension. The pneumatic tyres (12 psi) on all wheels are of low hysteresis rubber, of light weight, with anti-shimmy ribbed threads.

POWER UNIT.

1.3. The engine is a Rotax twin-cylinder two-stroke of 462.8cc rated at 38 bhp at 5,200 rpm. (max. rpm 7,000). The drive utilises a purpose built gear box with a 2.58:1 reduction and a standard two-bladed mahogany propeller. The power unit is mounted on four Lord anti-vibration rubbers.

FUEL.

1.4. Fuel is fed from a single 24.4 litre fuel tank fitted with a self venting but leakproof cap and mounted behind the monopole and below the engine. 4 star petrol should be mixed with a good quality two-stroke oil at a 50:1 ratio. The tank has a fuelcock and filter, and the external pipes are fire-resistant. Fuel content is measured from a sight-gauge on the side of the tank.

FILTERED FUEL ONLY SHOULD BE ADDED TO THE FUEL TANK.

ENGINE CONTROLS.

1.5. The primary throttle control is foot-operated (forward for full power and rearward for power off) and complemented by the friction-damped cruise control hand throttle (forward on and rearward off) on the port side of the seat frame. The mixture control is on the starboard side of the seat frame (rearwards for choke on/forwards choke off). An ignition kill-switch (up for on/down for off) is fitted on the front seat base bracket immediately below the pilot's knees. The engine start system is a pull-start running from a pulley close to the front pilot's feet.

## FLIGHT CONTROLS.

1.6. The Pegasus Flash 2. microlight wing is controlled by standard 'weight-shift' techniques, although the speed of response and lightness of action should be borne in mind for those pilots converting from other makes of wing.

### Control Bar Movements

### Aircraft Response

Bar pulled rearwards	Nose pitched down - aircraft speeds up
Bar pushed forwards	Nose pitch up - aircraft slows down
Bar pushed across to the right	Aircraft rolls to the left
Bar push across to the left	Aircraft rolls to the right

Conventional 3-axis pilots unused to weight-shift control will find the control bar movement and resulting reaction confusing at first. They will have to positively think about all movements, particularly in stress situations. A few hours of flight time is usually enough to sort out control error action, but it is absolutely essential that 3-axis pilots undertake a weight-shift conversion course on a dual-control machine before flying the Pegasus Flash 2..

## STALL CHARACTERISTICS.

1.7. Fully loaded, the stall occurs at 25 knots and is clean and easily handled. As the speed is reduced, aft bar pressure increases, noticeably so immediately prior to the stall. You will also notice a slight nodding tendency and a stiffening of roll response. As the wing stalls, the nose pitches down and corrective action is to bring the bar back slightly to prevent the aircraft re-entering the stall state. If the control bar is held lightly enough to damp out oscillations, the aircraft will automatically recover from a stall and return to trimmed flight. Slight wing drop may be found but is easily corrected. The Pegasus Flash 2. wing is remarkably stable, and even if stalled in a turn will not spin, but pitch down, increase air speed and roll out into a shallow turn or straight flight.

## GENERAL FLIGHT CONTROL.

1.8. It is important that the wing is tuned to ensure equal wing section and therefore balance trim (See pages 15 and 16). A wing which exhibits a constant turn when flying 'hands off' will be tiring to fly and uncomfortable in turbulence, particularly when landing or taking off. A properly tuned wing will fly completely 'hands off' throughout the whole range of power settings, although a slight tendency to turn owing to the torque reaction of the engine will always be present. The roll control response will increase as the speed increases, and turns are very easy to co-ordinate. Prior to moving the bar sideways to roll, speed should be increased by pulling back slightly. Once the aircraft has started to roll it should be pitched around the turn by moving the bar forwards. This action should be a smooth, fluid action; the bar movement completely related to both speed and angle of turn. Steeper turn angles require more speed, more roll and more pitch. Shallow turns, less of all three. Great care must be taken to ensure both sufficient speed for the rate of turn required and to ensure that too much 'pitch' (bar forward is not applied or the wing will stall in the turn. Clean and co-ordinated roll control can be accomplished easily by thoughtful practice, and pays dividends in smooth and efficient flying.

1.8. Cont. Microlighting is, in general, a fair-weather sport but light rain has little effect on flying control. You will notice that the wing becomes heavier to fly and the stall speed increases slightly, but the effects are minimal. Ice, however, is more serious and can occur through icing meteorological conditions, or by flying a wing which is wet from the bag, without giving it time to dry out. Severe icing can affect handling and speeds markedly and at the first sign you should cease flying or fly below icing conditions.

#### TAKE OFF.

1.9. Take offs are straight forward and the wing will lift the weight and hence fly when the correct air speed is reached. The correct technique is to hold the control bar back slightly during the initial stages of the take off run so as to reduce the drag and increase the acceleration. At around 20 mph, allow the bar to move forward, and as the aircraft accelerates push forward slightly until the aircraft un-sticks. The Trike unit will swing forward under the wing, and a wise pilot will hold the aircraft's climb rate down until a safe climbout speed is reached. Never, ever push the bar full out holding it there as the aircraft claws its way skywards. Climbing on the propeller this way is inefficient, indicative of poor-piloting technique, and very dangerous in the event of turbulence or engine failure.

During all aspects of flight the aircraft must be flown so that in the event of engine failure or loss of power, safe landing areas are always within reach. Providing the aircraft is being flown sensibly, an engine failure is not serious, and any competent and well-trained pilot should be able to cope. Fully loaded the engine-off sink rate is around 300/400 feet per minute and increases rapidly as speed is increased.

#### LANDING.

1.10. The Pegasus Flash 2. copes well with cross-wind landings, but sensible pilots take great care to land exactly into wind wherever possible. Make your approach about 10 knots above the stall and be aware of wind gradient during strong wind days. The flare is conventional, but the light pitch response can cause over correction and 'ballooning'. As soon as the wheels touch down pull hard back on the bar which will eliminate bounce and slow down the aircraft.

**Note: AIRCRAFT FITTED WITH A FRONT FOOTBRAKE SHOULD NOT APPLY SAME AT SPEEDS ABOVE 10 mph.**

If a cross-wind landing is unavoidable, make a conventional approach, but be ready for the twisting of the Trike unit as soon as the rear wheels touch. Whenever possible use whatever into-wind distance you can use - i.e. across the runway, ground steering across wind when firmly on the ground. Cross-wind landings up to 8 knots should present no real problems, but exercise great care in stronger conditions, and because of the high torsional loads which can be imparted to the Trike upright tube and wing keel tube, always carry out a detailed inspection after every cross-wind landing.

#### GROUND HANDLING.

1.11. Flex wing microlights are unique to their ground handling ability. In winds over 5 knots, always turn the aircraft until one wing is resting on the ground which will help stabilise the craft until you are ready for flight. A ground picket or weight (fuel can or similar) is very useful to tie the wing tip to in order to prevent damage to the tip and to hold the

1.11 Cont.

wing steady. When taxiing cross wind do not make the mistake of letting the into-wind wing rise up as this will greatly increase the chances of the aircraft ground looping. Instead, try to hold the wings dead level as this will present the minimum obstruction to the cross wind. When taxiing down wind, push the bar out to prevent the wind getting under the sail and putting you out of control.

2. RIGGING.

2.1. Pilots should inspect their machines as they rig them, paying attention to the following:

- a. Cables -- kinks; missing or damaged thimbles; broken strands.
- b. Tubes -- bends; stress marks; cracks around holes.
- c. Steel components -- bends; rust; fractures.
- d. Moving Parts -- seizure.
- e. Engine -- bolts; throttle cables; seizure of carburettors.

2.2. The monopole upright should be raised and locked geometrically by pushing down on the seat-frame hinges. If there is some significant wind, fit the compression tube and tension the one-inch strap under the seat squab, and then run the engine: if the plugs are fouled, or if there is some other engine problem, remedial action can be taken without worrying about the control of the wing.

2.3. To convert the tandem seat for solo operation, release the velcro which secures the rear seat backrest to the upright monopole and locate the two webbing pockets built into the underside of the rear seat base. Lift the rear seat up and forwards until its base lines up with the front seat back-rest, then insert the two alloy tubes provided into the pockets and push fully home. The rear seat backrest can now be folded backwards to form a fairing secured by its velcro to the seat webbing. Ensure that the one-inch webbing under the seat squab is fully tensioned. After the rear seat harness is made secure, the aircraft is ready for single-seat operation.

WING RIGGING.

- i. Select a clean, dry area and lay the wing down, opening the zip to reveal the control frame and underside of the wing.
- ii. Open out the control frame and attach the corner joint.
- iii. Lift the wing from the front and rotate it so that the wing is now laying on the ground with the assembled control frame flat on the ground underneath.
- iv. Remove all the sail ties and open each wing about a metre. Lift the kingpost and, checking to ensure the wires are untangled, fit it into the nylon apex block through the hole in the top surface of the sail.
- v. Tension the rear fin wire over centre lever, ensuring that it clips down tightly.

#### WING RIGGING Cont.

vi. Open the wings in 4 stages, one wing at a time to prevent damage to the cross tube joints.

vii. Ensure that all wires are untangled and free from twist, particularly at the connections. Locate the cross tube tensioner cord and pull back as if to rig the wing, but do not attach the tangs, allowing the wing to relax in the fully-open position.

viii. Fit the battens starting with the in-board main battens and working out-board towards the tip. Do not force the battens if they seem hard to push fully down. Fit the double cords by hooking one loop in place and then pulling the other loop over, if necessary using the special batten hook provided. Once the main battens are in place and tensioned, fit the intermediate battens by locating the pocket with the batten upside down (camber to bottom) and then rotating it over the correct way (camber to top) and sliding it fully into the pocket. Sometimes it may be easier to leave difficult battens until the cross tube tension is applied. You may then find them easier to push fully home.

ix. The undersurface battens are also cambered but the camber is reversed towards the top battens. They are inserted by lifting the trailing edge and locating the pocket, pushing the batten fully into the pocket until it locates on the front side of the leading edge.

x. Finally, fit the nose batten in place, locking it behind the nut on the nose plate and seal back the Velcro flap.

xi. When all the battens are in place and tensioned, the main cross tube tension can be pulled on with the cord inside the rear fin. As the 2 wires are pulled back, locate the rear tang onto the location pin following with the front tang. Allow the tension cord to retract and fit the pins with safety rings to prevent the tangs releasing.

xii. Locate the tip sticks into the sockets, ensuring they are firmly down to the limit.

xiii. Raise the control frame by lifting the nose of the glider until the wing can be rocked back against the base bar, raising the control frame and allowing the nose wire catch to be fitted and pinned. This operation is helped by having a helper lift the keel at the rear at the same time as you lift the nose, both of you rocking the wing back over the control frame base bar.

In light winds the nose can be lowered and the wing allowed to rest on the nose and control frame whilst the full pre-flight rigging check is carried out. In turbulence or strong winds it is best to have a helper hold the wings level at the nose whilst the checks are carried out.

xiv. Roll the trike unit into position from the rear of the wing, fix the main hang bolt and back-up wire bolt, ensuring that the locking pins or rings are fitted through the bolt to prevent loss of the wing nuts.

xv. Put the trike propeller horizontal and lift the nose of the wing until the keel tube rests on the propeller hub. Lift the wing from the control frame base levering against the propeller hub until the folding seat frame of the trike unit can be locked down. This operation must be carried out with care and it helps to have a helper preventing the trike from rolling backwards (wheel chocks can help). Fit the compression tube and tension the one-inch strap under the seat squab, and then run the engine.

xvi. To convert the tandem seat for solo operation, release the velcro which secures the rear seat backrest to the upright monopole and locate the two webbing pockets built into the underside of the rear seat base. Lift the rear seat up and forwards until its base lines up with the front seat back-rest, then insert the two alloy tubes provided into the pockets and push fully home. The rear seat backrest can now be folded backwards to form a fairing secured by its velcro to the seat webbing. Ensure that the one-inch webbing under the seat squab is fully tensioned. After the rear seat harness is made secure, the aircraft is ready for single seat operation.

### 3. DE-RIGGING.

De-rigging is an exact reversal of the rigging procedure, but great care must be taken when rolling up the sail to ensure creases are kept to a minimum. Always use the special padding pads to protect the wing at the following positions:

- a) Around the trike hang block assembly;
- b) around the apex block and control frame top assembly;
- c) under the control frame corner joints and base bar end.

At least 4 sail ties are needed to hold the de-rigged glider firmly and these should be positioned as the folded glider is lying on the assembled control frame. At this stage the bag can be fitted so that as the wing is rolled over to dis-assemble the frame, the bag is underneath protecting wing and can be zipped up after the control frame has been folded. Hold the control frame with sail ties.

### RIGGING AND DE-RIGGING INSPECTION.

As you rig your wing, you should always be meticulous in your inspection of each component. This is the best time to see potential faults which may be missed when the aircraft is fully rigged. Never allow yourself to be distracted during assembly of your aircraft and always rig to a repeatable sequence. Do not rely on the pre-flight check to find faults, but look carefully at all aspects of your aircraft as you put it together.

After flight, and particularly if you have had a heavy landing or suspect damage may have occurred through ground handling or cross wind landings, you must inspect the aircraft thoroughly. Wires should be checked for damage and fatigue, tube for bends or dents and the sail for tears or abrasions. Please check the maintenance and repair section in this manual.



#### 4. INSPECTION.

4.1. Assuming the machine is now fully assembled and is ready for the final pre-flight checks. Start at the nose and move around the wing making the following checks:

- Nose catch secure and locked
- Leading-edge spar undented
- Cross-spar junction secure (zip flap closed)
- Sail secure on tip
- Washout rod secure and undamaged
- Batten secure
- Luff lines secure
- Crossboom tensioner secure
- Keel pocket and fin components undamaged
- Hang-point secure and freely rotating
- Control frame locked
- Control frame cables secure
- Luff lines secure
- Batten secure
- Washout rod secure and undamaged
- Crossboom junction secure
- Leading edge spar undented
- Nose batten and nose catch secure and locked
- Top rigging secure

4.2. After returning to the nose, move around the trike making the following checks:

- Ignition off; engine controls closed
- Compression tube secure
- Front tyre inflated and in good condition
- Front forks and suspension in good condition
- Drag links secure
- Axles secure
- Rear tyres inflated and in good condition
- Seat-frame secure
- Cables secure
- Control cables -- no kinks
- Engine mountings secure
- Exhaust secure
- Carburettor secure
- Propeller secure
- Plugs and leads secure
- Fuel tank secure; fuel pipe fitted; fuel contents
- Coolant at correct level, no leaks and radiator cap secure.
- Water Pump/Rotary Valve Gear Oil Reservoir level and cap secure.

The aircraft is now ready for engine starting procedures.

4.3. The preflight checks for the Pegasus Flash 2., apart from the final pre-start checks, may be incorporated with the rigging procedures in section 2. above. However, great care should be taken with wings which are left fully rigged, for checks cannot be omitted on that account, and the full inspection procedures should be followed. The design brief for the Pegasus Flash 2. called for easy inspectability, so those components not open to view may be reached from zipped inspection panels.

Attention should be paid to the following:

- a. The symmetry of the wing and the angle of the kingpost.
- b. All tubes straight, undented and without cracks.
- c. All cables unkinked, unfrayed and with undamaged sleeves.
- d. All nuts and bolts secure and locked appropriately.
- e. All quick-release fittings secure.
- f. Hang-point undamaged, heart-bolt and back-up strap secure.
- g. All sail seams intact, with no frayed stitching.
- h. No tears in the sail.
- i. Double check g. and h. in sail areas of high stress.  
Particular areas of high stress are:
  1. Both tip fabric areas including tip fastening.
  2. Both leading edge upper surfaces.
  3. At the nose of the wing check that the securing screws and grommets have not become detached from the sail.
  4. The trailing edge stitching, grommets and shock cords.
  5. Keel pocket, particularly at the point of attachment to the upper surface.
  6. Keel pocket to keel tube fastening.
  7. The point of attachment in the root area of the undersurface to the upper surface.
  8. All cable entry and exit points with particular regard to the rear upper rigging cable entry.
  9. The area above the cross spar centre box.
- j. Sail tension settings correctly aligned and symmetrical.
- k. Battens undistorted, undented and in good condition.

#### 4.2. TRANSPORTATION.

The majority of wear and tear will take place whilst your wing is being transported and we cannot emphasise enough, the necessity to support and protect this delicate piece of high technology. Unless you have a van or estate car, a front strut will be required to ensure even support along the length of the wing. This can be a simple wooden prop located on the bumper bar of your car, with a well-padded top piece at the same level as a roof rack support. We recommend 2 single bar racks of the type used for ladders and sailing dinghies. Each bar must be protected with rubber to prevent chafing and placed as far apart as the roof gutters will allow. Never use elastic hook ties, but use webbing straps or short lengths of rope to tie the wing firmly to the rack. Be careful not to tie too tightly as this will crush the fabric and cause creases and tension lines.

Make yourself aware of current highway legislation regarding over-hang and hazard warning flags or lights.

#### 5. POST FLIGHT CHECKS.

5.1. No sortie is complete until the post-flight checks are finished. This has particular importance after a heavy landing.

##### WING.

- a. All tubes straight and undented; all flying wires undamaged.
- b. Wingribs and battens undistorted, undamaged.
- c. No bolts bent or cracked.
- d. Sail untorn: check especially where wires pass through the sail.

##### TRIKE...

- a. No leaks from fuel system and engine.
- b. No leaks from coolant system.
- c. No leaks from Rotary Valve/Water Pump Gear lubrication system.
- d. No splitting, denting or delamination of the propeller.
- e. No cracking in tyre treads, nor evidence of creep around the rim.
- f. Remove any grass build up on the lower axle cables.
- g. Front springs elongation.
- h. No bolts bent or cracked.

#### 6. ENGINE STARTING.

6.1. The engine should not be started without a pilot being strapped in to a seat. Any passenger should also be strapped in and briefed. All controls should be checked closed and ignition should be off.

6.2. Ensure that the engine is primed with fuel. Unless the engine is hot, apply full choke. Check visually that the propeller area is clear and call "Clear Prop" loudly. Switch on the ignition when the area is clear, take hold of the starting handle, pull gently until it is felt to engage and lock, and then pull forcefully. Repeat until the engine starts. If the engine refuses to start, close the controls and switch off the ignition before investigation.

6.3. When the engine starts, increase the rpm to a little above tickover and gradually decrease the choke until the engine idles normally with the choke fully closed. Warm up the engine. **BEFORE FLIGHT A FULL-THROTTLE CHECK IS CARRIED OUT FOR AT LEAST TWO MINUTES.** If fitted the footbrake should be applied and the front of the aircraft should be held securely. During this operation the pilot must be mentally prepared to switch off the ignition at very short notice. If the engine is stopped after a period of running, the ignition should be switched off at tickover. Switching off at high rpm floods the engine and makes restarting difficult.

6.4. The engine maintenance manual should be consulted for information on Gearbox oil, Water Pump/Rotary Timing Valve Drive Gear oil reservoir levels and specification, carburettor tuning, timing etc.

## 7. AIRWORTHINESS OPERATING LIMITATIONS.

The CAA. requires the pilot to respect the following limitations:

- a. The aircraft is to be flown only under visual flight rules (VFR).
- b. The minimum equipment required to operate under VFR. conditions is:
  - 1 - Air speed indicator, and 1 - Altimeter (the altimeter may be a wrist altimeter worn by the pilot).
- c. Aerobatic manoeuvres including whipstalls, stalled spiral descents and, negative g's are not permitted
- d. Do not pitch nose up or nose down more than 30 degrees from the horizontal.  
Do not exceed more than 60 degrees of bank.
- e. 

Max empty weight	150 kgs.
Max take off weight	344 kgs.
Min total occupant weight	71 kgs.
Max total occupant weight	180 kgs.
Max number of occupants	2
When flown solo the aircraft must be flown from the front seat only.	
Vne.	89 mph.
Max wind operating conditions	21 mph.
Cross winds of upto 10 mph. at 90 degrees at Max AUW. have been safely demonstrated.	
No baggage allowed.	

## 8. MAINTENANCE.

8.1. The Pegasus trike has been designed to permit easy inspectability, and operators should have no difficulty in assessing problems or recognising damage if visual checks are carried out conscientiously. General care should include:

Washing down the tube work with warm water and a light detergent followed by rinsing with fresh water.

Fabric sponged with warm water and a mild detergent and rinsed with fresh water.

The pod and wheel spats washed and polished using commercially obtainable shampoos and polishes.

The cockpit area should have all litter removed.

8.2. Apart from the consequences of heavy landing, or of exceeding flight limitations, the major factors for attention are corrosion and fatigue. There is no inherent fatigue problem with the Pegasus trike, but excessive loads and vibration can weaken the structure, and a regular watch for hair-line cracks, most likely in areas under high stress, such as around bolt holes, will give warning. All trike components can be replaced with no difficulty: repairs can be undertaken by the Solar Wings factory.

8.3. Careful attention to the recommended rigging and derigging sequences will protect the wing from the risk of unnecessary damage. The wing must always be transported inside its bag, and the bag zip must face downwards to prevent the entry of rainwater. During transportation, or when stored on slings, the wing must be supported at its centre and at two points not more than one metre from each end. Supports should be softly padded, and any support systems used for transport, such as roof racks, must use attachment straps which are sufficiently secure to eliminate the possibility of damage from vibration and abrasions.

8.4. Discoloration of the metal may indicate corrosion. Salt is the most common cause, particularly after winter road journeys, or during seacoast operations. Parts affected by salt must be stripped and thoroughly cleansed before reassembly. Corroded components must be replaced, and the cause of the corrosion identified and eliminated.

8.5. The Dacron sailcloth may be cleaned with warm soapy water, but strong detergents must not be used. Thorough rinsing with plenty of clean water must follow. Never use chemical solvents. Ultraviolet radiation from strong sunlight can ultimately reduce the strength of Dacron, but this may be reduced to an acceptable level by careful consideration of the wing's use and exposure. In its bag the wing is fully protected.

#### 8.6. LUBRICATION.

TRIKE. The rear axle bearings should occasionally be lubricated using a commercial lithium based grease. Frequency of greasing will depend entirely on the amount of taxiing time.

The rear steering bar, foot throttle, cruise control and choke lever pivots should be lubricated with machine oil weekly.

All other bearings are life sealed and require no additional lubrication.

Refer to the engine manufacturers handbook for gearbox, Water Pump/Rotary Valve Drive Gear lubrication details.

#### 8.7. WING FABRIC.

Care and maintenance starts the very moment you take delivery of your wing. 50% of all damage and degradation of your wing will take place when it is being stored or transported. Packing away properly is the most important single thing you can do to extend the life, efficiency and safety of this fragile piece of high technology. Dumping it in the bag with a few ties round it is the fastest way to rub holes in the sail, abrade rigging cable and dent tube.

### 8.7. Cont.

Despite the best care you can take, you will still have accidents with the odd wall or wire fence or your protection pads may slip and you will be faced with slight damage to the fabric. Where this takes place depends on how it can be repaired, high load areas such as a trailing edge being critical. Any cuts or tears through the trailing edge, sail fixing points or similar high load areas must be repaired at an approved workshop. Small damage to panels, leading edge cover etc. can be repaired with self adhesive tape which is cut to size, pressed into place on the clean dry sail and warmed gently with a hair dryer to melt the adhesive, being careful not to apply too much heat. We define small damage as abraded holes no more than 10mm diameter and small cuts no longer than 15mm. Anything larger should be inspected by a qualified engineer.

### 8.8. STITCHING DAMAGE.

All the seams are firstly joined with a double sided sail adhesive tape and then double zig zag sewn. Thread damage never ever gets better and eventually runs. Since the wing is held together with stitches, its pretty obvious what will happen when the stitching fails. If you abrade a seam, then have the damage repaired before it gets worse. Small non loaded areas can often be repaired in-situ by the tedious but effective method of hand sewing back through the original stitch holes. Never use anything but matching polyester thread which is available from Solar Wings or any good workshop or sail makers.

### 8.9. CLEANING.

The best answer to dirty sails is to keep them clean, but if all else fails and you need to wash your wing, then select a dry day and have access to a good hose and clean water supply. Never use strong soaps or detergents since soap residue can re-act with ultra violet light and degrade your fabric. We recommend a very mild liquid soap (washing up liquid) and a soft sponge. Gently wash the fully rigged wing, frequently hosing clean. Copious amounts of clean water will not harm the wing and can be very beneficial in removing sand and grit which may get trapped inside the leading edge pocket usually in the nose or wing tip areas. Ensure the wing is completely dry before de-rigging.

### 8.10. AIRFRAME.

#### i. TUBES.

The rules applying to the fabric also apply to the aluminium airframe. Care and consideration in de-rigging and transportation will pay huge dividends in airframe life. Any damage to any one of the structural members is serious and can usually only be repaired by replacement. Tubes suffer from abrasion or indentation, the first accelerating fatigue fracture and the second reducing the strength of the part by a massive amount. If you bend, dent or damage the tubular members in any way, seek immediate professional advice before flying again and have replacement parts fitted.

#### ii. BOLTS and NUTS.

All the bolts are AN series airframe bolts and only these type should be used for replacement. Any bolt which is bent or shows sign of corrosion should be immediately replaced. Nylock nuts should only be used once and wire locked nuts must be re-locked into place.

### iii. RIGGING WIRES.

The main danger with the rigging lies in kinking the wire, again caused by bad de-rigging. Once a wire has a kink, the strands are damaged and replacement is the only cure. The side wires are particularly important and should receive a frequent detailed inspection. Check for wire damage along the length but the main failure area lies immediately adjacent to the swaged fitting. Look carefully for signs of strand fracture at this position. Corrosion is a serious problem particularly in coastal areas and shows itself as a white powdery deposit. Corrosion cannot be cured and replacement is the only answer.

### iv. FITTINGS.

Most fittings on the Pegasus Flash 2. are manufactured from aluminium alloy and then anodised. Damage can occur through scratching or by the stress of an unduly heavy landing or crash, or by general wear. Look for elongated holes and stress lines in the aluminium. Damaged items should be replaced.

### v. BATTENS.

Battens form the wing shape and hence dictate the whole performance of the wing. They need treating with care, and since they are subject to constant tension both during flight and rigging, tend to lose their shape and flatten out. It is essential that they are reformed at frequent intervals and checked against the template. The best way to reform is to hold the batten against your knee and, whilst applying pressure to bow the batten, slide it side to side over the area you want to bend. Direct point bending will usually result in either a poor shape or a broken batten.

Refer to trimming notes on pages 15 and 16.

## 9.0 AIRFRAME LIFE AND MAINTENANCE SCHEDULE.

The whole concept of the flex wing microlight revolves around the ability of the wing to distort and change shape to accommodate the flight loads and to be controllable in flight. The airframe is designed to be non-rigid, and designed strongly enough to be able to flex in this way for the lifetime of the aircraft. However, "lifetime" is very subjective and is being constantly extended as microlight development catches up with materials and operational limitations. Not very long ago "lifetime" was often under 100 hours, whereas today (1986) 300-hour airframes can be easily found. Very few aircraft have over 500 hours, but they are around. No doubt in 2 years we will know of airframes with over 1,000 hours, but the reality of today is that, despite tests, experience and calculation, no-one quite knows how well the various components will stand up to the constant flexure, vibration and atmospheric corrosion the airframe is subjected to throughout its life. Constant cyclic loading cause fatigue, and fatigue shows itself as hairline cracks and fractures. Fatigue can be greatly accelerated by vibration which can result from poor propeller balance, or by poor flying techniques.

### 9.1. RECOMMENDED INSPECTION SCHEDULES.

TRIKE AND WING: Major complete strip down and inspection: 200 hours.

Solar Wings strongly recommends all parts to be visually inspected and assessed by an approved Solar Wings or BMAA inspector and repairs to be carried out as outlined in section 10.

**TRIKE: ENGINE:** (For inspection schedules refer to the engine manufacturers manual.)

Engine mountings: Cracks, bond failure and reduced stiffness: 25 hours.  
Engine controls: Cable fraying, adjustment and operating freedom: 25 "  
Engine electrical connections: Tightness and corrosion: 25 "  
Engine airfilters: Wash with clean petrol and resoak with 40:1 mix:10 "

**FUEL SYSTEM:**

Fuel filters: Clean or replace if necessary: 25 hours.  
Fuel lines: Cracks end fitting security and joints. 25 "  
Fuel tank including vents: Clean and check vent function: 25 "  
Fuel pump diaphragm: Check for cracks and signs of perishing: 50 "  
Fuel tank: Remove and flush out with clean petrol. 10 "

**TRANSMISSION:**

Propeller: Check for leading edge damage, delamination and splits: 25 hours.  
Propeller: Check propeller fasteners for tightness: 10 "  
Gearbox bearing: Check for play: 50 "  
Gearbox oil level: 10 "

**FRAME:**

All tube work: Check for bent and damaged tubes: 50 hours.  
Drag links and all fixing: Elongation of holes and tube damage: 50 "  
Seat frame and seat belts including  
hinge plates and dome bolts: Tube cracks and elongation of holes: 25 "  
Seat base bracket: check for damage and welds: 50 "  
Hang point bolt and bush: Check for wear and damage: 25 "

**CABLES:**

All cables: Check for broken strands, thimble damage and stretch: 25 "

**STEERING:**

Front forks: Check for straightness, elongation and cracks: 25 "  
Connecting link: Check for cracks, and rod end security: 25 "  
Rear steering bar pivot: Check for cracks and straightness: 25 "

**WHEELS AND TYRES:**

Tyres: Check for splits, perishing and pressures: 25 "  
Wheel hubs: Check for damage: 25 "  
Wheel bearings: Check for play and grease: 25 "

**BODYWORK:**

Pod: Check for Splits and general soundness: 50 "  
Spats: Check for splits and general soundness: 50 "  
Side fairing: Check for general soundness: 50 "

**WING: FRAME:**

Visual check on all exposed parts and those parts accessible through inspection zips: Check tube and fastener condition: 25 hours.

**CABLES:**

Lower: Check for broken strands, thimble damage and stretch: 25 hours.  
Upper: Check for broken strands, thimble damage and stretch: 25 hours.  
Restraint: Check for broken strands, thimble damage and stretch: 25 hours.

**FASTENERS:**

All fasteners: Check for wear, straightness and signs of fatigue: 25 hours.

**NOTE:** These inspections do not obviate the need for the Pre-flight and Post flight inspections outlined in sections 4 and 5 and the heavy landing inspection outlined in para. 9.8.



## 9.2. HEAVY LANDING INSPECTION:

After a heavy landing the inspections outlined in section 4 and 5 should be undertaken paying particular attention to the following points:

- Hang point bolt.
- Hang point bracket
- Monopole hang point bush.
- All tube work.
- Undercarriage cables and thimbles.
- Stub axles.
- Front forks and springs.
- Wheels and tyres.

## 10. REPAIR.

### 10.1. WING.

No repairs are to be undertaken by the operator.  
Sail repairs are only to be undertaken by the Solar Wings factory.  
Repairs by replacement only.  
Replacement parts must be obtained from Solar Wings Ltd. or a Solar Wings appointed agency.  
Bent aluminium tubes must never be straightened, always replaced.  
Frayed cables and cables with damaged or twisted thimbles must be replaced.

### 10.2. TRIKE.

No repairs are to be undertaken by the operator.  
Repairs by replacement only.  
Replacement parts must be obtained from Solar Wings Ltd. or a Solar Wings appointed agency.  
Bent aluminium tubes must never be straightened, always replaced.  
Frayed cables and cables with damaged or twisted thimbles must be replaced.

## 11. TUNING THE WING.

### NEW AIRCRAFT.

ALL NEW AIRCRAFT ARE FLOWN AND SET UP BY EITHER THE FACTORY OR BY APPOINTED AGENTS. PRIOR TO DELIVERY TO THE CUSTOMER, A FULL CHECK FLIGHT IS CARRIED OUT AND ADJUSTMENTS MADE TO THE WING TO ENSURE IT FLIES HANDS OFF AT THE RIGHT SPEED AND IS PROPERLY TRIMMED OUT. OWNERS ARE DISCOURAGED FROM MAKING ANY ADJUSTMENTS AND IF YOU FEEL YOUR NEW PEGASUS FLASH 2. IS NOT PERFORMING AS IT SHOULD, IT IS ESSENTIAL THAT IT IS RETURNED TO THE FACTORY FOR CHECKING.

THE FOLLOWING NOTES ARE FOR GUIDANCE ONLY AND SINCE TUNING OF FLEX WINGS IS A COMPLICATED AND EXACTING SCIENCE, NO ADJUSTMENT SHOULD BE MADE WITHOUT A FULL UNDERSTANDING OF THE PRINCIPLES INVOLVED.

### 11.1 WING TRIM.

A well tuned wing will fly in a straight line hands off and will respond to control inputs equally in each direction. However, fabric can stretch

11.1. Cont. slightly with age and battens can alter shape and get bent or distorted. The most common problem with flex wings is the tendency for the wing to acquire a turn one way which can be irritating and tiring on a long flight. Turns like this can almost always be tuned out and are invariably due to batten shape. However, it may be that airframe damage has occurred so the first thing to do is to check the frame carefully, inspecting for bends and distortion particularly in the leading edges. If the frame is alright, you should check the battens against the template and adjust accordingly. If the battens match the template, the fault may be due to wing stretch and you may have to compensate by altering the battens beyond the template shape. Maximum allowance is 15mm.

Example: Wing turns to the right, the right wing tends to drop. Solution, increase lift on the right wing by increasing the camber slightly. Remember that the effect is greater towards the tip, so a small amount out on the tip battens will probably cure the problem immediately.

Always carry out small adjustments and check fly between each one. A turn as described above may also be due to increased washout on the right wing and a serious case of an insoluble turn may be cured by altering the tension on the leading edge by adjusting the tip fixing bolt position. If a turn is incurable by making small adjustments, it may be necessary to return the wing to our approved agents or ourselves to have it checked out and corrected.

#### 11.2. PITCH TRIM.

Adjustment to trim is made by moving the nylon trike block on the wing keel. Moving the block forward will increase the 'hands off' speed and rearwards decrease it. The Pegasus Flash 2. wing requires very little adjustment to pitch and alterations from the test flown and checked status should not be made without consultation with the factory or our approved agents.

#### 11.3. LEECH LINES.

The whole pitch stability of the aircraft depends on the leech lines and no adjustment should be made without consultation with an approved organisation. Incorrect leech line adjustment can be exceedingly dangerous.

#### 11.4. MAINTENANCE AND REPAIR.

**WARNING** - THE PEGASUS FLASH 2. AIRFRAME IS DECEPT VELY SIMPLE, BUT LIKE ALL AIRCRAFT REQUIRES SKILLED AND QUALIFIED ATTENTION. WE DO NOT RECOMMEND SELF REPAIR OR RE-ASSEMBLY BY OTHER THAN FACTORY NOMINATED REPAIR AGENTS. NO REPLACEMENT PARTS SHOULD BE FITTED UNLESS THEY ARE FACTORY SUPPLIED AND IDENTIFIED.

12.

\*\*\* GENERAL INFORMATION SHEET \*\*\*

TRIKE:

Length (erect):	106.5 ins	271 cm
Length (fold down):	104 ins	264 cm
Width:	69 ins	175 cm
Track:	63 ins	160 cm
Height (erect):	100 ins	254 cm
Height (fold down):	66 ins	168 cm
Weight (dry):	214.5 lbs	97.5 kg
Max Hang Point Load:	644 lbs	293 kg
Minimum payload:	156 lbs	71kg

ENGINE:

Model.	Rotax 462 Liquid Cooled.
Capacity	462.8 cc
Max Rpm.	7000 Rpm.
Max Continuous Rpm	6500 Rpm.
Max Cylinder head Temp.	180 Degrees centigrade
Fuel Tank Capacity.	24.4 Litres.
Usable Fuel.	24.05 Litres.
Unusable Fuel.	0.35 Litres.

FILTERED FUEL ONLY TO BE ADDED TO THE FUEL TANK.

Fuel Petrol/Oil Mix Ratio:

Normal Use	50:1
------------	------

NOTE:

For all other engine data refer to the engine manufacturers handbook supplied as a supplement to the aircraft operators handbook.

RUNNING GEAR: Tyre Pressures.

12 psi

PLACARDS AND LOCATIONS:

Flight Limitations.

Upperside of base tube in front of Front Pilots seat.

Engine Limitations.

Upper side of base tube in front of Front Pilots seat.

Aircraft Weights.

Upper side of base tube in front of Front Pilots seat.

Fuel Type and Mix Ratio.

Adjacent to Fuel filler cap.

Fuel Capacity.

Adjacent to Fuel level indicator.

Fuel Cock On/Off Positions.

On Fuel Filter Bowl.



Ignition Switch On/Off Positions.

On Ignition Switch.

MAIN PLACARD.

FUEL PLACARD.

<b>SOLAR WINGS LTD</b> MANCHESTER W.L. 1873-1884	
MODEL	PEGASUS FLASH 2
<b>FLIGHT LIMITATIONS</b>	
MAXIMUM AVAILABLE PAYLOAD	195 Kg.
MINIMUM PAYLOAD	71 Kg.
DO NOT EXCEED V <sub>max</sub>	89 mph.
DO NOT PITCH NOSE DOWN OR NOSE UP MORE THAN 45 DEGREES FROM HORIZONTAL OR EXCEED 60 DEGREES ANGLE OF BANK.	
FLY SOLO FROM FRONT SEAT ONLY	
NO NEGATIVE G OR AEROBATIC MANOEUVRES	
NO WHISPALLE	
NO STALLED SPINAL DESCENTS	
<b>ENGINE LIMITATIONS</b>	
FUEL MIXTURE RATIO	50:1
<b>AIRCRAFT WEIGHTS</b>	
DRY EMPTY WEIGHT	148.5 kg
MAXIMUM TAKE OFF WEIGHT	344 kg
Wing Serial No.:- TANK SERIAL No.:-	

FUEL CAPACITY	24.4 lt
MIXTURE	50:1
FUEL ON	
FUEL OFF	
RECOMMENDED FUEL 97 OCTANE 4 STAR NON DETERGENT OIL TO BE USED	

WING.

Wing Span:

34.6 feet

Sail Area:

167.6 sq. ft

Aspect Ratio:

7.1

Weight:

51.0 kg

RECOMMENDED COMPONENT LIFE:

Crossbooms	1000 hours
Leading Edges	1000 hours
Kingpost	1000 hours
Control Frame	1000 hours
Keel	500 hours
Rigging Wires	On inspection; one year; 250 hours

PERFORMANCE:

Wings Level Stall Speed at max. auw:	29 mph
Height Loss during Recovery at max. auw:	60 ft.
Wings Level Stall Speed at min. auw:	25.5 mph
Height Loss during Recovery at min auw:	60 ft.
30 Degree Banked Stalls at max auw:	30 mph
Height Loss during Recovery at max. auw:	100 ft
30 Degree Banked Stalls at min. auw:	25.5 mph
Height Loss during Recovery at min. auw:	50 ft.
Descent Rate Power Off at max. auw:	300 fpm.
Take Off Distance at max. auw:	598 ft.
Flight manoeuvre loads:	+4 g. -2 g
Vne:	89 mph.
Cruise:	49 mph.

Nº : DESCRIPTION

- 1 : NOSE PLATE
- 2 : SWAN CATCH CHANNEL
- 3 : L/E FRONT L/H
- 4 : L/E REAR L/H
- 5 : L/E FRONT R/H
- 6 : L/E REAR R/H
- 7 : REEL TUBE
- 8 : KINGPOST
- 9 : CONTROL FRAME SIDE
- 10 : CONTROL FRAME BASE
- 11 : C/FRAME APEX BLOCK
- 12 : C/FRAME EAR BRACKETS
- 13 : HANG STRAP CHANNEL
- 14 : TRINE PIVOT BUSH
- 15 : FIN TUBE
- 16 : FIN TUBE BRACKET
- 17 : CROSS TUBE L/H / R/H
- 18 : CROSS TUBE HINGE BLOCK
- 19 : TENSION WIRE PINS
- 20 : CROSS TUBE / L/E BOLT
- 21 : ROLLER TIP ASSY.
- 22 : ROLL TIP BALLRACE +SHELLS
- 23 : NOSE BATTEN
- 24 : MAIN BATTEN No 1
- 25 : MAIN BATTEN No 2
- 26 : MAIN BATTEN No 3
- 27 : MAIN BATTEN No 4
- 28 : MAIN BATTEN No 5
- 29 : MAIN BATTEN No 6
- 30 : MAIN BATTEN No 7
- 31 : MAIN BATTEN No 8
- 32 : MAIN BATTEN No 9
- 33 : INTERMEDIATE BATTEN No 1
- 34 : INTERMEDIATE BATTEN No 2
- 35 : UNDER SURFACE BATTEN No 1
- 36 : UNDER SURFACE BATTEN No 2
- 37 : TIP STRUT
- 38 : SIDE KINGPOST WIRE
- 39 : REAR FLYING WIRE
- 40 : FRONT FLYING WIRE
- 41 : SIDE FLYING WIRES (PAIR)
- 42 : FRONT KINGPOST WIRE
- 43 : REAR KINGPOST WIRE
- 44 : OUTER LEECH LINE
- 45 : CENTRE LEECH LINE
- 46 : INNER LEECH LINE
- 47 : CROSS TUBE TENSION WIRES
- 48 : UNDER SURFACE BATTEN No 3

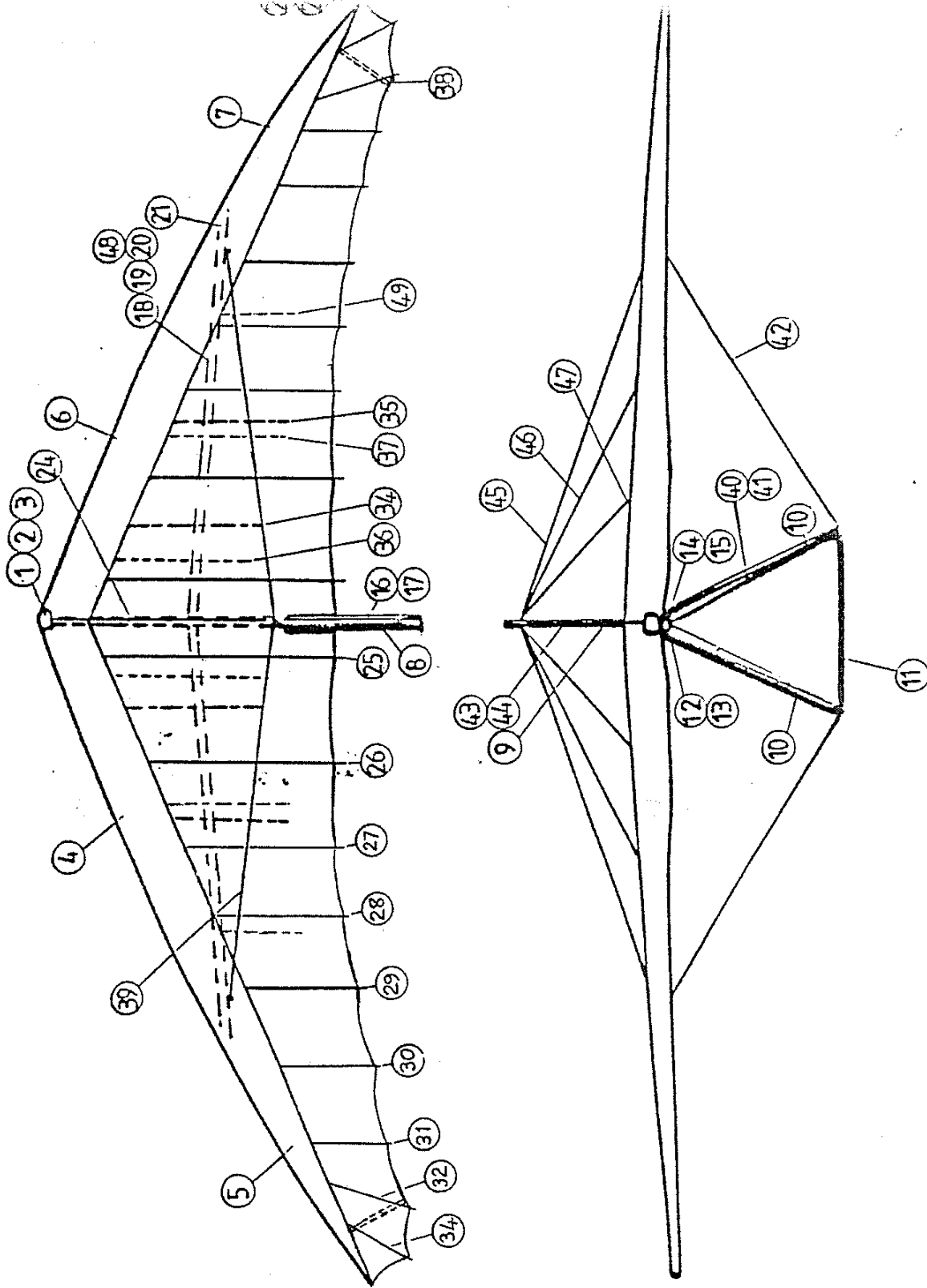

	SOLAR WINGS	SCALE NTS	TITLE FLASH WING GA
		DIMS N/A	DRG No. TR/FLASII
		GEN TOL ± N/	DATE MAY 1986
			DRN BY QQQD.
INITIAL			

8-5-86

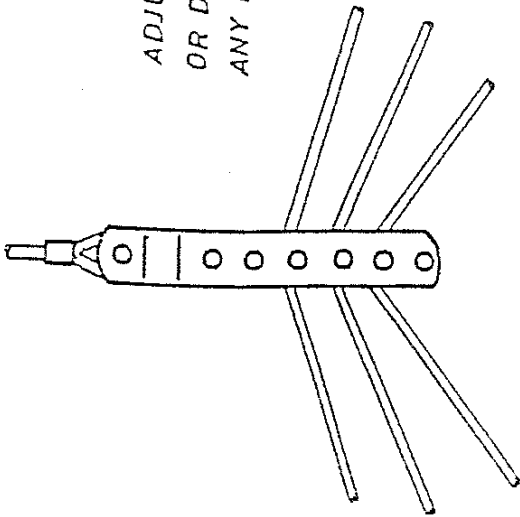

ADJUST LINES BY MOVING UP  
OR DOWN ON THE CLEVIS PINS  
ANY LINE CAN OCCUPY ANY POSITION

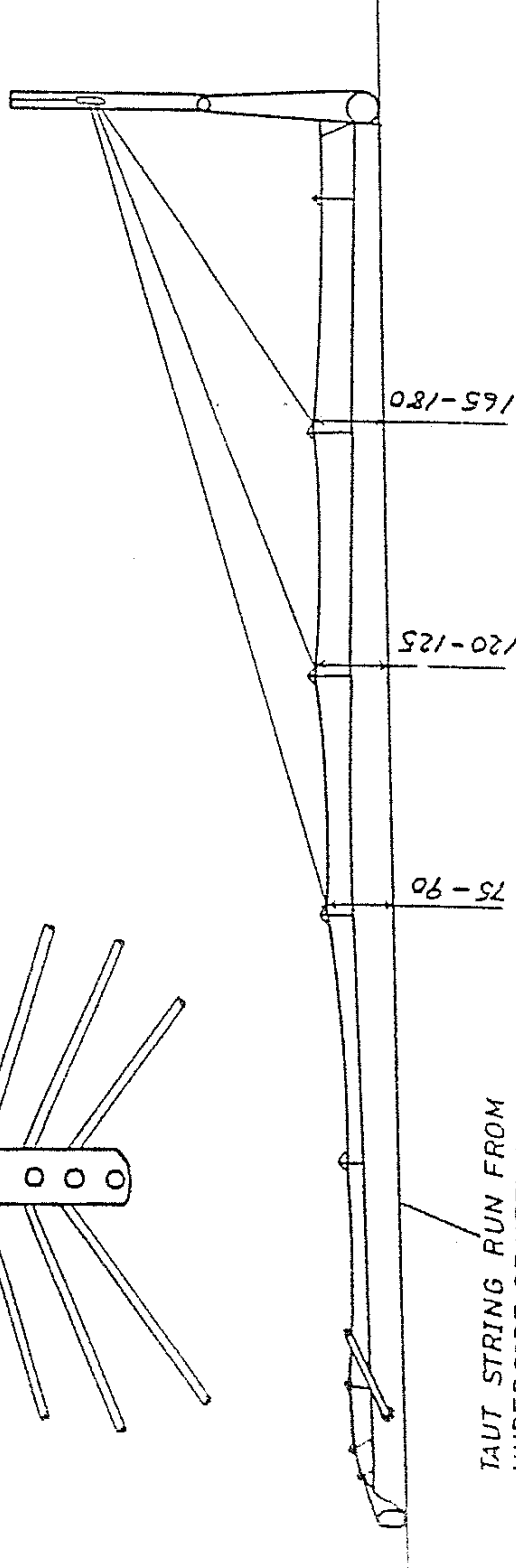

VIEW FROM REAR

TAUT STRING RUN FROM  
UNDERSIDE OF KEEL TO  
UNDERSIDE OF LEADING EDGE

NOTES.

- 1 THE DIMENSIONS SHOWN ARE APPROXIMATE, ACTUAL SETTINGS ARE INDIVIDUAL TO EACH AIRCRAFT AND ARE ESTABLISHED DURING FACTORY OR AGENT TEST FLYING.
- 2 OUTER LINES HAVE A GREATER EFFECT ON ROLL CONTROL AND HANDLING THAN THE INNER LINES.
- 3 AS THE WING SOFTENS WITH USE ADJUSTMENTS MAY BE REQUIRED.
- 4 ALWAYS ADJUST ONE LINE ONE HOLE AT A TIME AND THEN FLIGHT TEST.
- 5 DIMENSIONS ON BOTH SIDES OF THE WING MUST BE IDENTICAL AND BE MEASURED AT THE SAME TIME.
- 6 POSITIVE BAR PRESSURE MUST BE MAINTAINED AND THE AIRCRAFT TRIMMED OUT AT THE AIR SPEEDS GIVEN IN THE MANUAL

INITIAL		9-5-86		SOLAR		WINGS		DIM'S		SCALE N.T.S.		TITLE	
								mm		DATE 9-5-86		LEECH LINE SETTING	
								GEN TOL ±		DRG No.			

SOLAR WINGS LTD.

APPENDIX 1. OPERATORS HANDBOOK.

PEGASUS FLASH 2.

ROTAX 462 LIQUID COOLED ENGINE.

FOOT OPERATED BRAKE.

**DESCRIPTION:**

To prevent the aircraft rolling further than desired during taxiing on hard surfaces and slight inclines, a simple foot operated brake acting on the front wheel tyre, has been introduced. The brake also acts as an added safety feature during engine run-up. The mechanism consists of a spring return, foot operated lever, which pivots on the left fork and applies frictional force via a metal tubular arch to the top of the front tyre.

**OPERATING LIMITATIONS:**

**TAXIING:**

- (i) The foot brake **should not** be applied at speeds above 15 mph.
- (ii) To avoid the possibility of tipping the aircraft over, **do not apply the foot brake when the aircraft is being turned during taxiing.** The foot brake should only be applied whilst the aircraft is travelling in a straight line.
- (iii) Due to the drop in braking efficiency in wet and icy conditions, extra stopping distance should be allowed for.

**ENGINE RUN-UP:**

- (i) Operators should note that above 4100 engine rpm the aircraft may tend to creep forward.
- (ii) Due to the drop in braking efficiency in wet and icy conditions, allowances should be made by the operator for creep to occur at a **lower rpm** than stated in (i) above.

**INSPECTION:**

The amount of wear that takes place on the tyre and footbrake will vary from one aircraft to another, depending on the type of surface the aircraft normally takes off and lands on. **Close inspection** of the contact area of the brake should be made at intervals of no less than 5 hours.



SOLAR WINGS LTD

SERVICE BULLETIN

no. 0025 iss. 1

Date 27/09/89

---

SUBJECT : Flight Limitations.

---

MODELS AFFECTED : Pegasus Flash, Pegasus Flash 2.

---

CLASSIFICATION : The content of this Service Bulletin has been classified by the CAA as Mandatory.

---

COMPLIANCE TIME : Compliance is required with effect from receipt of this bulletin.

---

PURPOSE :

Since 1985 there have been five accidents to microlights employing the Mainair Flash series of wings (Flash, Flash 2, Flash 2 Alpha, Pegasus/ Mainair Flash 2) which have involved loss of control in flight with resultant catastrophic structural failure. In two of these accidents the microlight was seen by one or more witnesses to be in turning flight at the moment that loss of control occurred.

Of the remaining three accidents: there were no witnesses to two of them at the moment of catastrophe; in the third the microlight was seen to have been climbing steeply, wings level, when the engine stopped and a tumble and structural failure ensued.

It appears probable that some of these accidents may have been the result of the aeroplane being flown beyond the permitted limit of 60° bank angle, either inadvertently or deliberately. This is the limit to which microlight aeroplanes are required to be tested for certification. Mainair consider that a bank angle of 45° will give a safe margin to prevent 60° being exceeded accidentally.

The maximum angle of bank is now limited to 45 degrees.

In addition the maximum pitch angle is limited to 30 degrees.

It is emphasised that aerobatic manoeuvres on all types of microlight are prohibited. This includes: whipstalls, wingovers, tailslides, loops, rolls and spins.

Turns up to a maximum angle of bank of 45° are permitted but aggressive handling of the controls, particularly during reversal from bank in one direction to the other, must be avoided as this can induce rapid rates of roll with a high risk of the bank angle limit being exceeded.

SOLAR WINGS LTD

SERVICE BULLETIN

no. 0025 iss. 1

Date 27/09/89

---

The aircraft must be flown such as to maintain positive normal acceleration (positive 'g') at all times.

Enclosed with this Service Bulletin is an amended page for incorporation into the Operators Handbook.

Issue 2 of this Service Bulletin will follow shortly with an amended placard and an additional amended page for the operators handbook.

W. G. Brooks (Chief Designer).

A handwritten signature in black ink that reads "W.G. Brooks". The signature is written in a cursive, slightly slanted style.

SOLAR WINGS LTD

SERVICE BULLETIN

no. 0025 iss. 1

Date 27/09/89

---

The aircraft must be flown such as to maintain positive normal acceleration (positive 'g') at all times.

Enclosed with this Service Bulletin is an amended page for incorporation into the Operators Handbook.

Issue 2 of this Service Bulletin will follow shortly with an amended placard and an additional amended page for the operators handbook.

W. G. Brooks (Chief Designer).

A handwritten signature in black ink, appearing to read "W.G. Brooks". The signature is written in a cursive, slightly slanted style.

6.3 When the engine starts increase the rpm to a little above tickover and gradually decrease the choke until the engine idles normally with the choke fully closed. Warm up the engine. **BEFORE FLIGHT A FULL THROTTLE CHECK IS CARRIED OUT FOR AT LEAST TWO MINUTES.** If fitted the footbrake should be applied and the front of the aircraft should be held securely. During this operation the pilot must be mentally prepared to switch off the ignition at very short notice. If the engine is stopped after a period of running the ignition should be switched off at tickover. Switching off at high rpm floods the engine and makes restarting difficult.

6.4 The engine maintenance manual should be consulted for information on Water Pump/Rotary Timing Valve Drive, Gear oil reservoir levels and specification, carburettor tuning, timing etc.

#### 7. AIRWORTHINESS OPERATING LIMITATIONS.

In accordance with Condition no. 4 of the Permit to Fly, the aircraft must be operated in compliance with the following limitations:

- a. The aircraft is to be flown only under visual flight rules (VFR).
- b. The minimum equipment required to operate under VFR conditions is:
  - 1 Airspeed Indicator and 1 Altimeter (the altimeter may be a wrist altimeter worn by the pilot).
- c. All aerobatic manoeuvres including whipstalls, wingovers, tailslides, loops, rolls and spins are prohibited. The aircraft must be flown such as to maintain positive normal acceleration (positive 'g') at all times.
- d. Do not pitch nose up or nose down more than 30 degrees from the horizontal. Do not roll in excess of 45 degrees of bank angle with respect to the horizontal. Aggressive handling of the controls, particularly during reversal from bank in one direction to the other must be avoided as this can induce rapid rates of roll with a high risk of the bank angle limit being exceeded.
- e. 

Max empty weight	146 Kg
Max take off weight	344 Kg
Min total occupant weight	71 Kg
Max total occupant weight	180 Kg
Max number of occupants	2
When flown solo the aircraft must be flown from the front seat only.	
Vne	89 mph.
Max wind operating conditions	21 mph.
Cross winds of up to 10 mph at 90 degrees at Max AUV have been safely demonstrated.	
No baggage allowed.	

#### 8. MAINTENANCE.

8.1 The Pegasus trike has been designed to permit easy inspectability and operators should have no difficulty in assessing problems or recognising damage if visual checks are carried out conscientiously. General care should include:

Washing down the tubework with warm water and a light detergent, followed by rinsing with fresh water.

Fabric sponged with warm water and a mild detergent and rinsed with fresh water.

The pod and wheel spats washed and polished using commercially obtainable shampoos and polishes.

The cockpit area should have all litter removed.

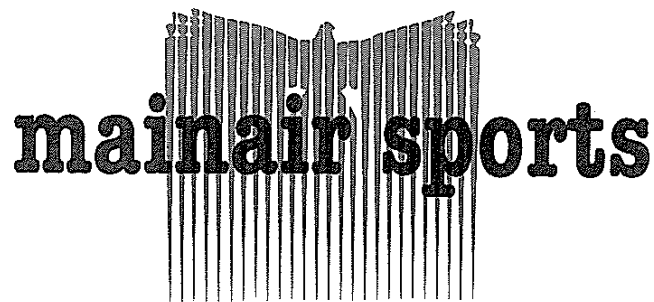

Service Bulletin No: 43

Issue: 2

Date: 20th June 2000

Applicability: Gemini Flash 2, Gemini Flash 2 Alpha & Mainair Mercury

CAA Classification: Mandatory

Action: Before Next Flight

#### Details

The Gemini Flash 2, Gemini Flash 2 Alpha and Mainair Mercury wings have a number of adjustments that can be made to the wing settings, this enables owners to fine tune the handling of the aircraft. However because of the large number of adjustments that can be made it is also possible to adjust the wing such that the characteristics of the aircraft can be altered beyond that which has been tested and approved. There must be no extra shackles at the ends of any of the leech lines, and any such additions are not approved and invalidate the Permit to Fly. It is therefore required that all owners of the above aircraft check that the wing settings are as per the factory settings and that the basic handling is within the correct limits.

The procedure to ensure that the wing settings are correct are as follows:

**Wing Battens:** Ensure that these match the wing batten profile, slight variation is allowed as indicated on the batten sheet, this is to correct any turn. All owners should have a copy of the batten sheet, as this is a requirement of the Permit to Fly renewal.

**Index Tips:** These should be set in the normal position, which is marked with an 'N' and is the second hole from the top. See enclosed diagram.

**Leech Lines:** These must be set to within the limits as shown on the attached sheet. These can only be measured with the wing rigged, and after the batten profiles have been checked. The method for measuring these is to tie some string around the wing tip and routing beneath the wing sail towards the keel. This must then be pulled tight to remove all slack and looped around the keel, from beneath, at the front of the fin, and then carried onto the other wing tip where it must be tied off. As indicated on the enclosed diagram. The wing must be approximately level. Using a retractable tape, the settings can be measured by hooking the tape over the trailing edge of the wing at the leech line in question and sighting the string in-line with the bottom of the keel. The reading from the tape must be taken and the corresponding reading from the other side of the wing must also be measured and the average

calculated. This gives the setting for the leech line. This must be checked against the range as indicated on the attached sheet. All three leech lines must be measured and compared to the required readings. Adjustments can be made by altering the settings using the seven hole adjuster near the king post. Remember that altering one line can affect the other settings so all three will require measuring again. If the settings cannot be made to match the correct figures then the factory must be consulted, for advise.

All settings must be recorded in the Airframe Log Book.

Flight Test: This must be carried out on a calm day. The aircraft must be rigged correctly as indicated in the operators manual. The aircraft must be flown dual and solo, remember to keep above the minimum cockpit load of 70kg. The hands off speed must be checked for the aircraft and for the Gemini Flash 2 must be between 43 and 53 mph and for the Gemini Flash 2 Alpha & Mainair Mercury must be between 45 and 55mph. There must also be a positive bar pressure when the bar is pulled back and speed increased. **A pull back force of at least 5kg must be required for a speed increase of 10mph.** A record of the figures found must be recorded in the aircraft log book. The trim speed can be adjusted by altering the hang point position, which has three adjustment holes, and typically gives a change of upto 5 mph to the hands of speed.

If there is any doubt in checking any of the above your BMAA inspector should be able to carry out the ground checks for you and a BMAA check pilot should be able to conduct the simple flight test. Alternatively the wing can be returned to Mainair Sports for the checks to be carried out, contact the factory for details.

Upon completing the above an entry must be made in the airframe log book, stating that you have checked your wing against Service Bulletin 43, and that the wing settings are as per the factory setting.

At the next Permit Inspection Renewal, the BMAA inspector should be made aware of the Service Bulletin and should confirm that you have carried out the above procedure correctly, also during the check flight the BMAA Check Pilot should confirm that there is a positive pitch force change with change in airspeed.

Owners are reminded that no flex wing microlight is aerobatic and must only be flown within the prescribed limits as contained in the aircraft manual. Failure to fly within the correct limits may cause loss of control.

If you are no longer the owner of the Gemini Flash 2, Flash 2 Alpha or Mercury referenced on the address label, please forward this bulletin onto the new owner.

Inc. Drawings FGA-77 & FGA-78

A handwritten signature in black ink, consisting of stylized initials and a surname, located at the bottom of the page.

DWG NO. FGA-77

TITLE  
LEECH LINE  
MEASUREMENT

DATE 20<sup>th</sup> APR 00

SUPERCEDES

DRAWN BY *[Signature]* CHECKED BY *[Signature]*

REF	DATE	AMENDMENT
A	21-6-00	NEW DRAWING FOR SETTINGS ISSUED

SEE FGA-76 FGA 78  
FOR SETTINGS

MAINAIR SPORTS LTD.  
TEL: 01706 655134

TOLERANCES UNLESS STATED OTHERWISE  
GENERAL ± 0.25mm DIMENSIONS ± 0.05mm

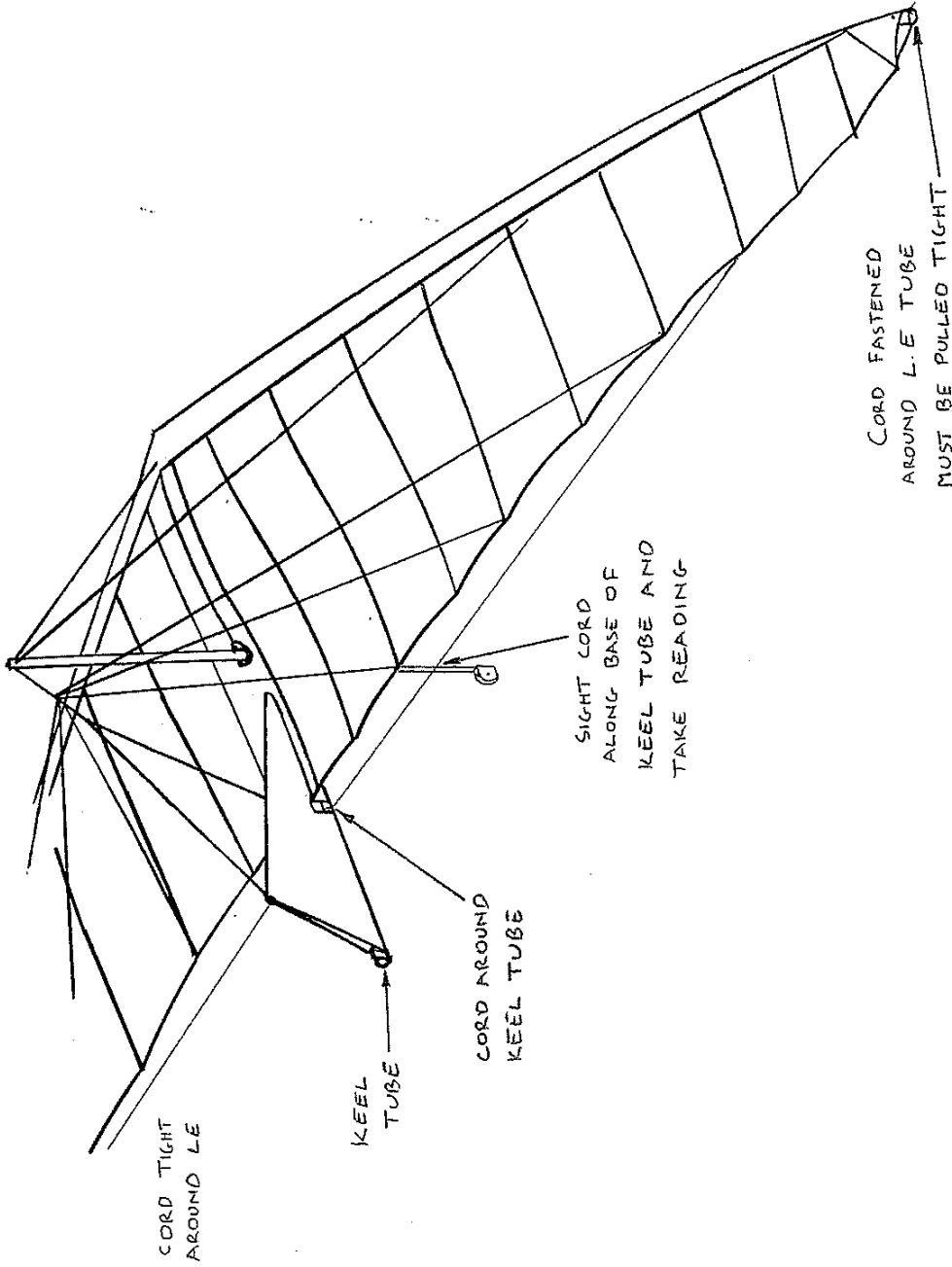

(A)

**NOTES ON ADJUSTMENT**

1. The dimensions shown are approximate and are established during initial factory or agent check flight
2. The outer lines have more effect on roll control & handling than the inner lines
3. As the wing softens with use adjustments may be required. Always adjust one line, one hole at a time & flight test after each adjustment
4. POSITIVE BAR PRESSURE MUST BE MAINTAINED AND THE AIRCRAFT TRIMMED OUT AT THE CORRECT AIR SPEEDS IN THE MANUAL

R. Hand Tip Shown.

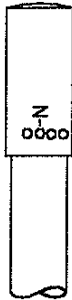

Index Tip Normal Position Shown Marked With 'N'

Roll Pin, fitted in lower hole in kingpost top fitting.

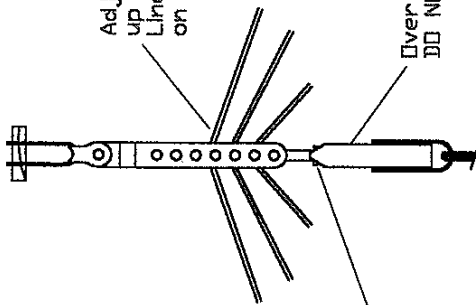

Top rigging tension adjustment Ensure that at least 5 full threads engaged in adjuster.

VIEW FROM REAR OF WING

Top/Rear Rigging

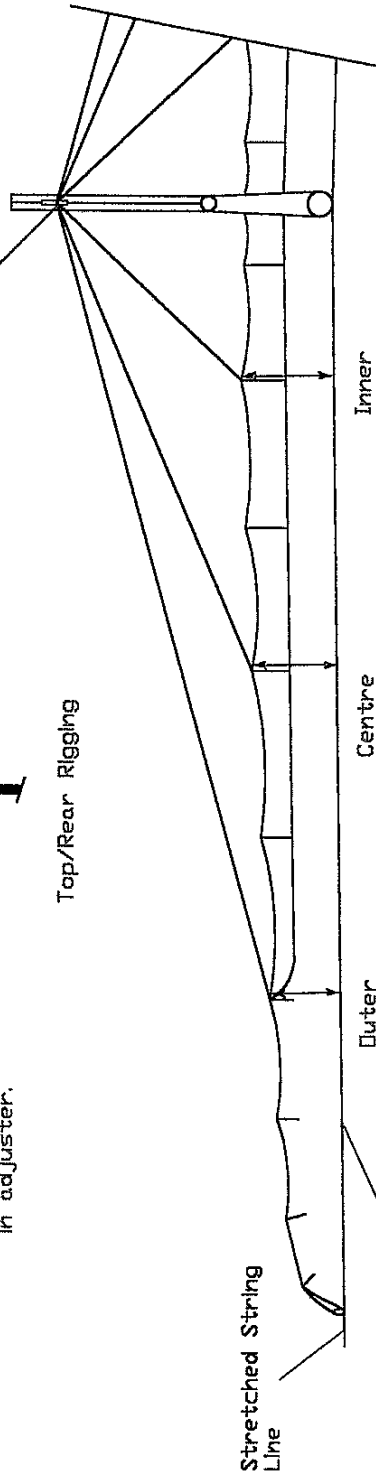

DWG NO. FGA-78

TITLE Flash2 & Alpha Leech Line Settings

DATE 21st June 2000

SUPERCEDES FGA-76

DRAWN BY [Signature] CHECKED BY [Signature]

REF DATE AMENDMENT

New Drawing Tolerance Limits Changed To Allow For Wing Sail Stretch

See Drawing FGA-77 For Measurement Method

MAINAIR SPORTS LTD. TEL: 01706 655134

TELEGRAMS: UNLESS STATED OTHERWISE CENTRES & LINES DIMENSIONS ± 0.00MM