

mainair sports

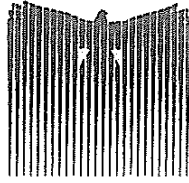

Mainair Sports Ltd
Unit 2, Alma Industrial Estate, Regent Street,
Rochdale Lancs. OL12 0HQ England
Telephone: Rochdale (0706) 55134
Telex: 635091 Albion G-Attention/Mainair
Fax: (0706) 55135

Date: 11 September 1990

GEMINI FLASH 1, FLASH 2,

MICROLIGHT MANUAL Doc Ref GF Manual Issue 4

Contents

- Page 1. Delivery Check List
- 2. Noise Type Certificate
- 3. Warning Notice
- 4. Amendment Record
- 5. Specifications
- 6. Blank
- 7. General Information
- 8. General Information
- 9.
- 9. Load Distribution & CG & GA. Drawing
- 10. Pre-flight Check List
- 11. Blank
- 12. Operation Procedure
- 13. Operation Procedure Continued
- 14. Rigging
- 14A. Rigging & Flight Trimming
- 15. Running In & General Maintenance
- 16. General Maintenance Continued
- 17. Maintenance, Care & Cleaning Continued
- 18. Multi-blade propellers
- 19. Blank
- 20. Maintenance Schedule
- 21. Maintenance Schedule Continued
- 22. Blank
- 23. Record of Running Hours
- 24. Modification and Part Failure Log
- 24. Annual Airworthiness Inspection
- 24. Owner List
- 25. Maintenance Record
- 25. Incident Log
- 25.
- 26. Electrical System
- 27. 27a. Fuel System Upright Engine
- 28. Wing Adjustment Drawing
- 29. Hang Point Adjustment
- 30. Leech Line Adjustment

Aircraft Details

Registration _____
Serial number _____
Date _____
Batten issue _____
Customer _____
Dealer _____
Invoice _____
Engine No _____

This manual covers the following aircraft:

GEMINI FLASH 1 and FLASH 2



FINAL DELIVERY INSPECTION CHECK LIST

Wheels Front

Fully greased

Bolts tight

Free running

Inflated correctly

WHEELS FROM STUB

Brake Correct

Front Fork

Steering head tight

Main bolt tight

Pivot greased

Mudguard secured (if fitted)

Brake bolt tight: ~~04165-04~~

Rubbers fitted

Accelerator Cable fixed & wired

Spring fastened correctly

Nut caps

Pull Start

Knot tight

Pulley free running

Bolt tight

Nut caps fitted

Seat Frame

SEAT STRAPS TIGHT

Bolts tight at keel

Bolts tight at channel

Tangs fitted on Remstraps

Folding joint bolts tight & wired

Spacer fitted at joint

Nut caps fitted

SEAT WOOD

COUNTY FOOT REST / REAR STEERING

Bolts tight

Rubbers fitted

Nut caps fitted

End plugs fitted

Cockpit

Nose Strut fitted

Rear supports

Dash mounting

Nut caps fitted

Map pocket fitted

Windscreen fitted

Strips and name

Fabric Rear

Tank Inlet

Spats

Check fitted (No Tank Contact)

Nut washer & plug

Engine Cover

Fitted Correctly

Rubber feet

Keel Vertical Strut Junction - Mk II

Bolts tight and wired

Pulleys free

End caps fitted

Nut caps fitted

SEAT FRAME TELESCOPES DRILLED

Keel Axles

Bolts tight - and locked

End caps fitted

Nut caps fitted

Axle side struts

Ear brackets tight & mouldings fitted

Bolts tight

Axle tie wire O.K. (if fitted)

Side Struts

Bolts tight "P" CLIP FITTED

Rubber suspension greased or Damper O.K.

Ear brackets correct top & bottom

Main channel bolt tight

Limitation wires fitted (if fitted)

Wheels - rear

Both greased

Both retained correctly (split pin open)

Inflated correctly

Free running

Propeller

Bolted tight (or supplied assembled)

Nut caps

Prop disc - FIT WITH LINES TO 3 ENGINE AXLES

Prop tape

Reduction Drive

Pulley alignment checked

Belt fit to teeth checked

Main bolts and front bolts tight

Drive pin in main pulley or bolts wired

Belt correct fit

Belt tension correct

Bearing housing bolt all tight

Check top and lower nuts

Nut caps fitted

Bearing unit greased

Spark Plugs fitted and elastic

Rotax Engines

Oil filled & wire locked

Drain plug wired

Breather pipe clipped

Prop disc & hub drilled out & tight

Inlet muffler supported & retained

RADIATOR MIRR & CAP SEALS

TOP Engine Mounts

Main bolts tight

Rubber mount correctly fitted

Rubber mount bolts tight

Nut caps fitted

LOWER Engine Mounts

Main bolts tight

Rubber mount bolt tight

Nut caps fitted

Engine Rigging

Bolts, tight on thimble eyes

Nut caps

Engine Electrics

Parts located & placed correctly

Fixing bolts tight

Cable strapped up and tie ends cut

Cables heat shrunk

Cable loops for folding O.K.

Spark plug caps retained

Connector screws tight & lid sealed

Engine Controls

2 into 1 wired throttle box checked

Foot throttle free

Hand throttle free

Choke cables free

Control fittings tight

Cables strapped & tie ends cut

Full throttle opening filter, tight & wired

Fuel Line

Smooth runs - no kinks in tube

Ends well fitted - Springs fitted

Filter fitted correctly

Breather fitted

Tank strapped tight - (HEX FIT)

Gauge fitted

(Quick-release elastic)

Second Tank fitted

Exhaust

Safety Tie wire

Nuts all locked & lock washers fitted

Rubber mounts tight

Rubber mounts not distorted

Prop clearance O.K.

Exhaust guard fitted

DISCONNECT FRONT STRUT, AND FOLD TRIKE DOWN

Airframe

Check keel/strut alignment

TOP Assembly

Bolts all tight

connector O.K.

Lock ring in top bolt

Rear engine rigging

Erect Trike

Fit front strut

Check bolt fit on front strut

Check rings & wing nuts

Check stickers - MAS & flag

Throttle placard CORRECT WAY !!

Tank placard FUEL RATIO CORRECT

Main placard

Name plate

Test Run

Fuel 50 to 1 ROTAX

Check no leaks in fuel line

Check ignition contact

Check switch operation

Start and run at least 5 minutes

General Check over

Additional Parts

Engine manual - check engine type

Instruction book and plastic folder

Serial number

Constructors initial

Tool kit with:

plug spanner and rod,

screwdriver and spanner,

Prop bag - fit to check length

Invoice No. on plans and recorded

Transit tag + Prop P.C.S. - SERIAL TAG

Seat Belts

Instruments

Winter A.S.I.

Thomson Altimeter

Red line on engine ints.

TEMP GAUGES

Checked by.....

Agent check.....

Date / /

Serial No. --- -- -- W

DISCONNECT FRONT STRUT, AND FOLD TRIKE DOWN

**United Kingdom
Civil Aviation Authority**

Noise Type Certificate

Aircraft Type Certificate Number: 128

Name and Type Designation of Aircraft: Genair Flash Sprint 2 Center Winglight

Manufacturer: Maimair Sports Ltd.

It is hereby certified that the type of aircraft named in this certificate is acceptable for United Kingdom noise certification. The basis for certification is stated below. Approved variants and their power plants, their maximum noise certificated weights and the corresponding noise figures are as stated on the reverse.

ECAR Section II Issue 3 Chapter 03-5, 2, 3.

[Signature] for the Civil Aviation Authority
20th March 1985 original Date of Issue
20th March 1985 Date of this Issue No. 1



Approved Variant	Date of Approval	Power Plant	Noise Figures SEL in dBA		
			Takeoff	Approach	Flyover
Maimair Genair Flash	20-3-85	Rotax 447 Fan cooled inverted. Maimair 62" dia. 35" Pitch Propeller Pacox Underwing 2x90" Muffler 2.58:1 Reduction Gear			80.7
Maimair Genair Flash	20-3-85	Rotax 447 Fan cooled inverted. Maimair 62" dia. 35" Pitch Propeller Pacox Underwing 2x90" Muffler 2.58:1 Reduction Gear			80.9
Maimair Genair Flash	20-3-85	Pull Robin E204PM inverted Maimair 62" dia. 30" Pitch Propeller Maimair Rotaflow Muffler 2.66:1 Reduction Gear			78.2
Maimair Genair Sprint	20-3-85	Pull Robin E204PM inverted Maimair 62" dia. 30" Pitch Propeller Maimair Rotaflow Muffler 2.66:1 Reduction Gear			78.8

CA 1007
10/84

**United Kingdom
Civil Aviation Authority**

Noise Type Certificate

Aircraft Type Certificate Number: 274

Name and Type Designation of Aircraft: GENAIR FLASH 447

Manufacturer: MAIMAIR SPORTS LTD

It is hereby certified that the type of aircraft named in this certificate is acceptable for United Kingdom noise certification. The basis for certification is stated below. Approved variants and their power plants, their maximum noise certificated weights and the corresponding noise figures are as stated on the reverse.

ECAR SECTION II ISSUE 3 CHAPTER 03-5, 2

[Signature] for the Civil Aviation Authority
13TH MARCH 1986 original Date of Issue
13TH MARCH 1986 Date of this Issue No. 1

Approved Variant	Date of Approval	Power Plant	Noise Figures SEL in dBA		
			Takeoff	Approach	Flyover
Genair Flash 447	13-3-86	Rotax 447 mounted upright with 2.58:1 reduction gear Maimair 62" diameter 35" pitch propeller Rotax Intake Muffler Part No. 825357 Intake Air Filter Part No. 825510 Side mounted exhaust manifold Part No. 879495 exhaust muffler Part No. 973158 after muffler Part No. 878372			80.9

**United Kingdom
Civil Aviation Authority**

Noise Type Certificate

Aircraft Type Certificate Number: 284

Name and Type Designation of Aircraft: GENAIR FLASH 447

Manufacturer: MAIMAIR SPORTS LTD

It is hereby certified that the type of aircraft named in this certificate is acceptable for United Kingdom noise certification. The basis for certification is stated below. Approved variants and their power plants, their maximum noise certificated weights and the corresponding noise figures are as stated on the reverse.

ECAR SECTION II ISSUE 3 CHAPTER 03-5, 3

[Signature] for the Civil Aviation Authority
18TH MARCH 1986 original Date of Issue
18TH MARCH 1986 Date of this Issue No. 1

Approved Variant	Date of Approval	Power Plant	Noise Figures SEL in dBA		
			Takeoff	Approach	Flyover
Genair Flash 447	18-3-86	Rotax 447 mounted upright with 2.58:1 reduction gear Maimair 62" diameter 35" pitch propeller Rotax Intake Muffler Part No. 825357 Intake Air Filter Part No. 825510 Side mounted exhaust manifold Part No. 879495 exhaust muffler Part No. 973158 After muffler Part No. 878372			79.6

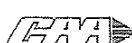

CA 1007
10/84

**United Kingdom
Civil Aviation Authority**

Noise Type Certificate

Aircraft Type Certificate Number: 25M

Name and Type Designation of Aircraft: GENIUM FLASH 503 (FLASH 2 AND FLASH 2A)

Manufacturer: MAHAIR SPORTS LTD.

It is hereby certified that the type of aircraft named in this certificate is acceptable for United Kingdom noise certification. The basis for certification is stated below. Approved variants and their power plants, their maximum noise certificated weights and the corresponding noise figures are as stated on the reverse.

BCAR Section II Issue 3 Chapter H3-5.3

P.R. King for the Civil Aviation Authority
13th March 1986 original Date of Issue
25th June 1987 Date of this Issue No. 2



Approved Variants	Date of Approval	Power Plant	Maximum Noise Certificated Weight		
			Take-off	Approach	Flare
			Landing	Noise Figure	
Geniun Flash Geniun Flash 2 Geniun Flash 2A	13 March 1986	Rotax 503 mounted upright with 2.68:1 reduction gear Malnaric 62" diameter 49" pitch propeller square tip Rotax Intake Muffler Part No. 825337 Intake Air Filter Part No. 825510 Side mounted Exhaust Manifold Part No. 873144 Exhaust Muffler Part No. 873158 After Muffler Part No. 878372			79.7

**United Kingdom
Civil Aviation Authority**

Noise Type Certificate

Aircraft Type Certificate Number: 31U

Name and Type Designation of Aircraft: 402 GENIUM FLASH, FLASH 2 & FLASH 2A

Manufacturer: MAHAIR SPORTS LTD.

It is hereby certified that the type of aircraft named in this certificate is acceptable for United Kingdom noise certification. The basis for certification is stated below. Approved variants and their power plants, their maximum noise certificated weights and the corresponding noise figures are as stated on the reverse.

BCAR Section II Issue 3 Chapter H3-5.3

P.R. King for the Civil Aviation Authority
9th July 1986 original Date of Issue
25th June 1987 Date of this Issue No. 3

Approved Variants	Date of Approval	Power Plant	Maximum Noise Certificated Weight		
			Take-off	Approach	Flare
			Landing	Noise Figure	
Geniun Flash Geniun Flash 2 Geniun Flash 2A	9 July 1986	Dombador Rotax 462 liquid mounted upright with high performance valve plate part no. 524 205 Malnaric propeller with 62 inch diameter 46 inch pitch round tip or 62 inch diameter 46 inch pitch square tip or 62 inch diameter 44 inch pitch round tip or 3 blades having 62 inch diameter 107" pitch at 12 inches from centre K & N Intake muffler and Rotax exhaust pipe after muffler Intake muffler Part No. 825337 Intake air filter Part No. 825510 Side mounted exhaust manifold Part No. 873144 Exhaust muffler Part No. 873158 After Muffler Part No. 878372	Cooled		70.4 73.9 70.7 70.2

**United Kingdom
Civil Aviation Authority**

Noise Type Certificate

Aircraft Type Certificate Number: 50M

Name and Type Designation of Aircraft: 503 GENIUM FLASH, FLASH 2 & FLASH 2A

Manufacturer: MAHAIR SPORTS LTD.

It is hereby certified that the type of aircraft named in this certificate is acceptable for United Kingdom noise certification. The basis for certification is stated below. Approved variants and their power plants, their maximum noise certificated weights and the corresponding noise figures are as stated on the reverse.

BCAR Section II Issue 3 Chapter H3-5.3

P.R. King for the Civil Aviation Authority
9th May 1987 original Date of Issue
25th June 1987 Date of this Issue No. 2

Approved Variants	Date of Approval	Power Plant	Maximum Noise Certificated Weight		
			Take-off	Approach	Flare
			Landing	Noise Figure	
Geniun Flash Geniun Flash 2 Geniun Flash 2A	8th May 1987	Dombador Rotax 503 mounted upright 3 bladed Malnaric propeller with 62" diameter and 107" pitch at 12" from centre K and N Intake muffler and Rotax exhaust pipe after muffler Intake muffler Part No. 825337 Intake Air Filter Part No. 825510 Side mounted exhaust manifold Part No. 873144 Exhaust muffler Part No. 873158 After Muffler Part No. 878372			77.3 dBA

SPECIFICATIONS

Max total all-up weight	- 344 kgs Flash 1 & Flash 2 -
Max occupant weight	- 180 kgs
Max load factor	- 4G P. 2G N. with 1.5 safety factor
Load composition	- 1 or 2 occupants
Min all-up weight	- 234 kgs
Fuel capacity	- 4.75 gallons (17kg) - or 9.5 galls with extra tank
Stall at min load (Height Loss)	- 22 knots (25MPH) (80')
Stall at max load (Height Loss)	- 24 knots (28MPH) (90')
Stall height loss at 30° bank	- 80 ft
Max nose down at stall	- 8°
Cruise speed	- 43 knots (49MPH)
Never-exceed speed (VNE)	- 77 knots (89MPH)
Min approach speed - engine at idle	- 36 knots (42MPH)
Best rate-of-climb speed	- 36 knots (42MPH)
Landing run at max load - clear 15 M obstacle	- 230M
Take-off run at max load - clear 15 M obstacle	- 181M
Climb rate fully laden	- 150M/min (500 fpm)
Climb rate min load	- 300M/min (1000 fpm)
Max wind operating conditions	- 18 knots (21 MPH)
Max cross wind conditions	- 8 knots at 90° (10 MPH)
Power off rate of descent	- 167M/min approx
Power off ground distance covered	- 1315M/min (7.84 : 1)

ENGINE OPTIONS	ROTAX 447cc Inverted	ROTAX 447cc Upright	ROTAX 503cc	ROTAX 462cc
Reduction type	2.58/1 gearbox	2.58/1 gearbox	2.581 gearbox	2.581 gearbox
Dry weight	146kg	146kg	147kg	149kg
Fuel Mix	50:1	50:1	50:1	50:1
Rec.max engine temp EGT	1,500 DegF	1,500 DegF	1,500°F	1,500°F
Rec.max engine temp CHT	425 DegF	425 DegF	425°F	425°F
Rec.max engine speed	6,800rpm	6,800rpm	6,900rpm	6,900rpm
Propeller	62x37RT 62x38RT	62x35 RT 62x40 RT	62x40RT 62x3-blade at 107°at 12"stn	62x44 RT 62x46 62 x 3-blade at 107°at 12"stn

Note: Recommended max engine temperatures and speeds can be exceeded for very short periods without immediate damage. However, you are strongly recommended not to exceed the limitations at any time. Engine speed (RPM), cylinder head temperature and exhaust gas temperature gauges are all available to enable accurate monitoring. If the aircraft is operated in accordance with the above specifications under ISA + 15°C max and the fuel air mix is correctly adjusted, the limits recommended will not be exceeded. Beware of high temperature days and long periods of stationery running.

PERMITTED MANOEUVRES.

Pitch angle - nose up/down not to exceed 30°. ALL AEROBATIC MANOEUVRES ARE PROHIBITED. including: Whipstalls, Wingovers, Tailslides, Loops, Rolls and Spins. Angle of bank not to exceed 45°.

GENERAL SPECIFICATIONS

Airframe	- multi sleeved 2 1/8" - 2" - 1 3/4" x 17 swg
	- Drawn seamless HT - 30 - TF Anodised.
Aluminium fittings	- NS8 sheet & H30 machined components
Bolts & Nuts	- Airframe bolts AN Series 3/16, 1/4, 5/16, & 3/8.
Rigging	- 7 x 7 x 4mm Stainless steel, 3 & 2 1/2mm coated 7x7 stainless steel.

Dimensions

Span	- 10.55
Height - Kingpost to Trike connection	- 1370
Height - Base bar to Trike connection	- 1500
Overall height	- 2870
Length - nose to tip of keel	- 3300
Rigged weight of wing	- 51 kg
Standard de-rigged length (wing)	- 6000
Short packed de-rigged length (Wing)	- 4500
Max suspended load from Trike connection (Wing)	- 300 kg
Wing stressed to + 4 - 2 with 1.5 safety factor at all up weight of 350 kg (+6-3)	

Dimensions - fully-assembled Flash Wing/Gemini Trike

Height - floor to kingpost top	- 3.83 Mts
Width - batten tip to top	- 10.6 Mts
Length - wing tip rear to cockpit nose	- 3.46 Mts

GENERAL INFORMATION1. Operating Limitations

This aircraft must be operated under visual flight rules (VFR) at all times. Minimum equipment to operate under VFR is as follows: Altimeter - recommend Winter. 0 to 10,000 feet. Airspeed Indicator - recommend Winter 0-100 MPH - Venturi type. Appropriate Maps - air charts for operational areas.

2. Cross Wind Conditions - Take off and Landing

Cross winds to 15 knots (17 MPH) have been demonstrated, but we would recommend an 8 knot (10 MPH) maximum. No special techniques are required, but be ready to correct steering direction on touch down, and to prevent the up-wind wing from rising.

3. Power off Landings

Maintain minimum airspeed of 36 knots (42 MPH). Ensure adequate obstacle clearance. Beware of landing short, and practice techniques under controlled conditions.

4. In-flight Re-start

We do not recommend switching off the engine during flight unless practising under controlled conditions. If it is necessary to re-start in the air, set approximately 20% throttle and do not use the choke if the engine is warm. Control bar positions should be neutral.

5. Load Distribution and C.G.

Maximum total all-up weight must not be exceeded. Single or dual seat occupancy will affect the control bar position slightly.

6. Flight Limitation Placards - Gemini/Alpha Trikes

The placard which details flight limitations is on the main keel tube immediately behind the front fork. The throttle direction placard is on the left hand seat frame adjacent to the throttle lever. The fuel tank placard is mounted on the rear of the engine cooling duct on aircraft fitted with a Rotax 503 engine, or on the radiator if fitted with a 462 engine. The placard for the long range fuel tank is on the side strut immediately adjacent to the fuel filler neck. The registration plate is fastened to the engine top mounting plate. The serial number is stamped on the end of the main seat channel.

7. Minimum Cockpit Load

The minimum cockpit load is defined to ensure full flight control of the aircraft. Sand ballast can be added if required in a special fabric container which attaches to the rear seat belt and airframe structure of Mainair manufactured trikes.

8. Fuel Tanks

4.75 gallon plastic - this tank fits behind the seat. To install, the tank seat support straps are slipped off the retaining tube at the main seat channel. Position the tank on the keel tube and locate in the metal strap which is fixed to the vertical strut. The tank strap fits underneath the keel, around the vertical strut and is pulled tight across the front of the tank so as to press the tank firmly onto the keel and into the bracket. Fit the hose connector and retaining elastic and prime fuel checking for leaks. Ensure the fuel line is not kinked or trapped and position the breather tube in the clip on the engine casing. The fabric cockpit has to be fitted over the filler neck and it may help to remove the gauge whilst doing this. After fitting and checking, slip the seat loops back up between the channel and seat frame back and locate them on the retaining tube.

9. Fuel Priming

Most machines are fitted with a fuel primer bulb if your model does not have this fuel priming is achieved by swiftly rotating the propeller backwards and forwards about 20° to operate the suction fuel pump. ENSURE THE IGNITION SWITCH IS OFF.

10. Rubber Suspension Bushes On Gemini Flash 1

The telescopic side struts contain rubber balls which acts in compression. These are lubricated at the factory with Rocol MX33 grease. They should be checked and re-lubricated every 50 hours.

11. Single Seat Operation

Ensure rear seat belt buckles are all firmly connected together to prevent them reaching propeller. Adjust seat strap until position is comfortable.

12. Upright Rotax Engines - Fuel Tank

The upright Rotax models have the main tank underneath the engine. The plastic seat tank therefore becomes the optional long range tank. The engine tank has exactly the same fittings and is removed for cleaning by detaching the right-hand engine strut at the ear bracket position, as shown on drg 99-00-303, page 27a.

13. Alpha Trikes with front rear suspension and drum brakes - 1987 models

Dust from the brake shoes must be cleaned out on a regular basis and the wheel bearings regreased. The brake can be adjusted on the cable nipples, as required.

Front suspension operates in self-oiled bushes but will benefit from a light oiling of the plunger. The centre fork pivot should also be oiled every 15-20 hours. The rear suspension spring unit should also be lightly oiled every 15-20 hours. The wheels are mounted on ball race bearings which are adjustable via a screwed cone. All wheels must be adjusted after the first 10 hours of operation and regularly checked afterwards by rocking side to side. Any movement should be adjusted out.

14. Tyre Pressures and Tyre Creep

Wheels should be inflated to 15 psi. Over inflation gives a harder ride but under inflation can lead to tyre 'creep' and inner tube valve failure. We recommend you paint a white line on the tyre and rim and check for 'creep' during your post and pre-flight inspections.

15. Maximum Braking Speed

The front or rear brakes are intended as power check and taxiing aids only - they should be operated with caution and not applied at speeds in excess of 15mph other than in an emergency. Air frame wear and tyre creep damage can occur from overuse of this light weight braking system.

GENERAL INFORMATION - continued

Carburettor Icing

Icing can and will occur in certain meteorological conditions. The air-cooled engines have a modification to allow the engine cooling air to be directed on the carburettor body. The 462 engine has a 'hot coil' system which warms the fuel and hence slightly raises the carburettor bowl temperature.

462 Engine Installation - Power Operation at Light Weight

The 462 engine installations are more powerful than the 447 and 503 air-cooled ones. When operating solo, pilots should take care to operate the throttle sensibly. Excessively steep climb outs are unsafe since they lead to nose-high altitudes and engine failure in this situation may result in insufficient time/height to recover.

In addition, engine failure at steep climb altitudes may lead to a whip stall or tail slide situation, which can and has resulted in structural failure and break up of the aircraft in flight. The flight limitations established for this aircraft must never be exceeded, and pilots are warned that the high power available with the 462 engine means greater care must be taken to ensure the limits are observed.

DWG NO.

TITLE GA GEMINI FLASH I

DATE

SUPERCEDES

REF DATE

AMENDMENT

PAGE 9

MAHAR SPORTS LTD

TEL: 0706 55134

TOLERANCES UNLESS STATED OTHERWISE
GENERAL ± 1.0MM DIMETERS ± 0.05MM
CENTERS ± 0.5MM

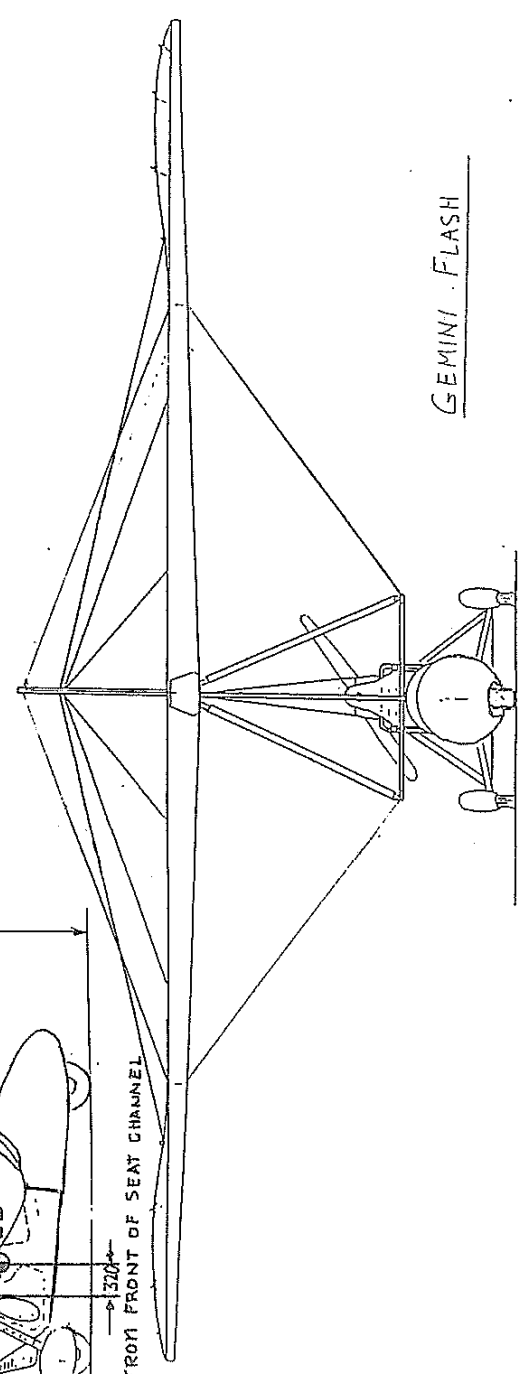
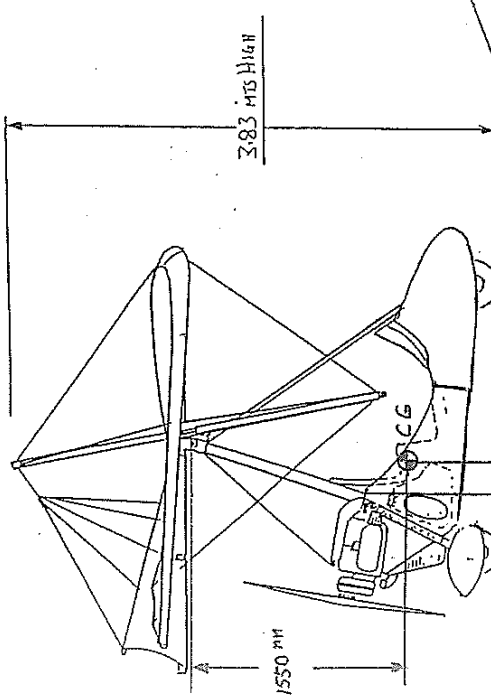
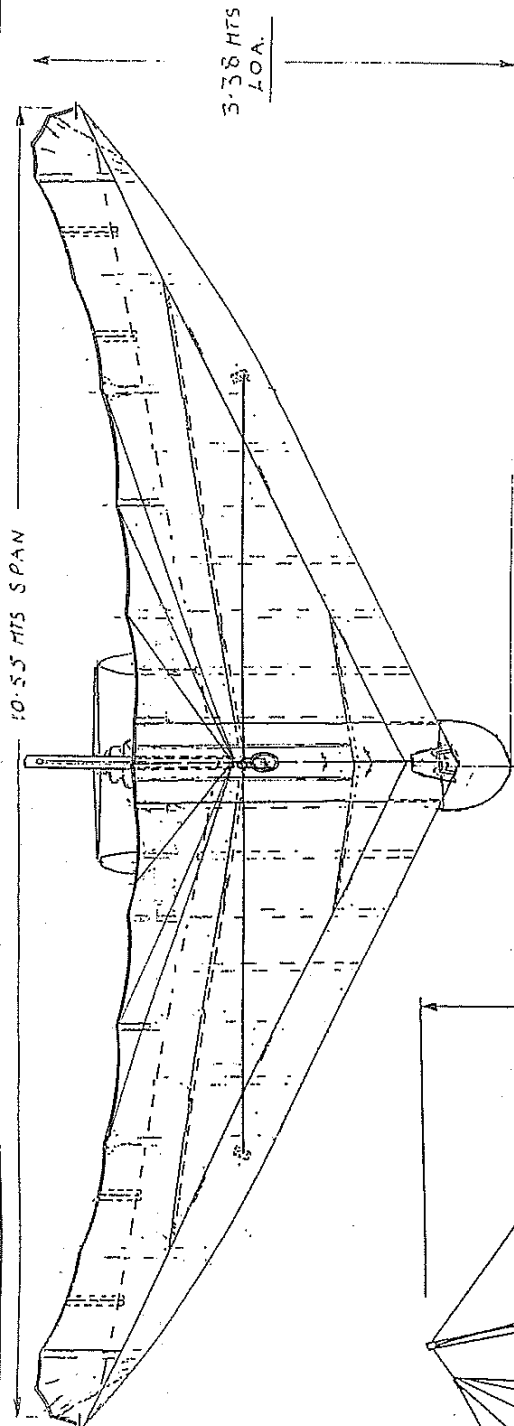

GEMINI FLASH

PRE-FLIGHT CHECK LIST

Wing

1. Apex block
2. Trike block
3. Control Frame
4. Side wires
5. Inspection panel
6. Left hand tip (check index pin located)
7. Trailing edges
8. Batten attachment
9. Keel and fin (check pull back pin rings located)
10. Right hand tip (check index pin located)
11. Side wires
12. Inspection panel
13. Nose fairing
14. Nose catch
15. Kingpost (check over-centre catch locked)

RIG WING TO TRIKE

Trike

1. Trike connection - ring fitted - fore aft location
2. Back-up loop
3. LH seat lock
4. Exhaust check
5. LH axle and wheel assembly
6. Gearbox
7. Prop fixing and blade check
8. RH axle and wheel assembly
9. Carb attachment - plug caps tight
10. Fuel line and connections - clean filters
11. Tanks secure and full - breather clear - correct tanks selected
12. RH seat lock
13. Rear seat fitting tube
14. Cockpit, instruments - required maps
15. Front strut
16. Nose wheel
17. Check non-wire lock nuts

PRIOR TO FLYING

1. Full control movement
2. Ignition off
3. Fuel primed - choke as required
4. Seat belts fitted
5. Helmets fixed
6. No loose items
7. Intercom clear
8. Prop clear
9. Start engine - run for minimum of 5 minutes
or until CHT reads 250° F min
10. Check clear prior to launch

AIR LAW

All microlight aircraft must operate within current air law. All pilots must familiarise themselves with air law, particularly with C.A.P. 85. Much of the U.K. is subject to flying limits, and there are many and varied air lanes and special areas around airports and similar installations. You should purchase a current air space map and familiarise yourself with the limits shown. Failure to comply with certain restrictions may result in a heavy fine and confiscation of the aircraft. Mainair Sports stock many useful publications and air maps.

TRANSPORT

Trike. - We recommend that the Trike unit be trailered to and from the flying field. on Mainair's Roadrunner trailer means that the Trike unit will be easy to load and safely transported utilising the tie downs for security. The Trike unit may be transported with a monopole upright in the rigged position, or folded down with the monopole resting on the transit 'Y' yoke. The long transit tie should be used to prevent the Trike unit rolling from side to side during transit. This should be fastened to one main axle leg, wrapped around the propeller transit insert (the tube fitted with a bright yellow flag) and fastened off to the other main axle leg.

Glider Wing. - Before the wing is transported make sure that it is correctly packed, and that the protection padding is correctly located. The wing may be transported on a vehicle roof-rack provided that some front support is provided for the wing overhang. Mainair supply a glider rider support system that conveniently attaches to the bonnet of the vehicle using suction pads, and is adjustable in height to suit different vehicles. A light weight aluminium ladder forms a convenient base to support the wing over its entire length. In the event of a vehicle that cannot be fitted with a roof-rack, the Mainair roadrunner trailer can be provided with wing support brackets. The wing should be secured with adjustable transit ties available from Mainair Sports Ltd.

OPERATING AREAS

Microlights are aircraft and should be operated as such. Stay away from populated areas which will be restricted by buildings, trees, power lines etc. Fly from airfields and open places, and if you have to consider whether a field is long enough to take-off in, it probably isn't. Take-off runs vary with the trike model and conditions, the air density of the day, and the pilot's skill and weight. Until you are totally familiar regarding the size of field needed, fly from recognised microlight airfields or huge open areas. Be ready for the engine to fail 50ft up and make sure you have lots of room ahead to make a safe landing. Treat your field and the population around it with consideration. Having gained all your initial experience elsewhere at a recognised site, launch from your field and then fly away. The quickest way to annoy people living near a used field is to continually fly in and out subjecting them to what is in reality, a pretty aggravating noise, especially at week-ends. If they hear you just once or twice during the whole day they are most unlikely to complain and you have a chance of keeping your field. Obey air law at all times and do not fly beyond your limits. Weather knowledge has to be learned. There are many useful publications on micro meteorology which should be studied. A wide range of books covering all aspects of microlight flying is available from Mainair Sports Limited.

FLIGHT CONTROL

The Gemini Flash is controlled by standard flex wing techniques, although the speed of response and lightness of action should be borne in mind for those pilots converting from other makes of wing.

Control Bar Movements

Bar pulled rearwards
Bar pushed forwards
Bar pushed across to the right
Bar pushed across to the left

Aircraft Response

Nose pitched down - aircraft speeds up
Nose pitch up - aircraft slows down
Aircraft rolls to the left
Aircraft rolls to the right

Conventional 3-axis pilots unused to flex wing control will find the control bar movement and resulting reactions confusing at first. They will have to positively think about all movements, particularly in stress situations. A few hours of flight time is usually enough to sort out control error action but it is absolutely essential that 3-axis pilots undertake a flex wing conversion course on a dual-controlled machine before flying the Gemini Flash.

Stall Characteristics - "See additional note page 13".

Fully loaded, the stall occurs at 24 knots and is clean and easily handled. As the speed is reduced, aft bar pressure increases and noticeably so immediately prior to the stall. You will also notice a slight nodding tendency and a stiffening of roll response. As the wing stalls, the nose pitches down and corrective action is to bring the bar back slightly to prevent the aircraft re-entering the stall state. If the control bar is held lightly enough to damp out oscillations, the aircraft will automatically recover from a stall and return to trimmed flight. Slight wing drop may be found but it is easily corrected. The Flash wing is remarkably stable, and even if stalled in a turn will not spin, but pitch down, increase air speed and roll out into a shallow turn or straight flight.

General Flight Control

It is important that the wing is tuned to ensure equal wing section and therefore balance trim. A wing which exhibits a constant turn when flying 'hands off' will be tiring to fly and uncomfortable in turbulence, particularly when landing or taking off. A properly tuned wing will fly completely 'hands off' throughout the whole range of power settings, although a slight tendency to turn owing to the torque reaction of the engine will always be present. The roll control response will increase as the speed increases, and turns are very easy to co-ordinate. Prior to moving the bar sideways to roll, speeds should be increased by pulling back slightly. Once the aircraft has started to roll it should be pitched around the turn by moving the bar forwards. This action should be a smooth, fluid action; the bar movement completely related to both speed, and angle of turn. Steeper turn angles require more speed, more roll and more pitch. Shallow turns, less of all three. Great care must be taken to ensure both sufficient speed for the rate of turn required and to ensure that too much 'pitch' (bar forward) is not applied or the wing will stall in the turn. Clean and co-ordinated roll control can be accomplished easily by thoughtful practice, and pays dividends in smooth and efficient flying.

Microlighting is, in general, a fair weather sport but light rain has little effect on flying control. You will notice that the wing becomes heavy to fly and the stall speed increases slightly, but the effects are minimal. Ice, however, is more serious and can occur through icing meteorological conditions, or by flying a wing which is wet from the bag, without giving it time to dry out. Severe icing can affect handling and speeds markedly and at the first sign you should cease flying or fly below icing conditions.

Take Off

Page 13.

Take offs are straight forward and the wing will lift the weight and hence fly when the correct air speed is reached. The correct technique is to hold the wing back slightly during the initial stages of the take off run so as to reduce the drag and increase the acceleration. At around 20 mph, allow the bar to move forward, and as the aircraft accelerates push forwards slightly until the aircraft un-sticks. The trike unit will swing forward under the wing, and a wise pilot will hold the aircraft's climb rate down until a safe climb out speed is reached. Never, ever, push the bar full out holding it there as the aircraft claws its way skywards. Climbing on the propeller this way is inefficient, indicative of poor-piloting technique and very dangerous in the event of turbulence or engine failure.

During all aspects of flight the aircraft must be flown so that in the event of engine failure or loss of power, safe landing areas are always within reach. Providing the aircraft is being flown sensibly, an engine failure is not serious, and any competent and well trained pilot should be able to cope. Fully loaded the engine-off sink rate is around 300/400 feet per minute and increases rapidly as speed is increased.

Landing

The Flash copes well with cross-wind landings, but sensible pilots take great care to land exactly into wind wherever possible. Make your approach about 10 knots above the stall and be aware of wind gradient during strong wind days. The flare is conventional, but the light pitch response can cause over correction and 'ballooning'. As soon as the wheels touch down pull hard back on the bar which will eliminate bounce and slow down the aircraft. If a cross-wind landing is unavoidable, make a conventional approach, but be ready for the twisting of the trike unit as soon as the rear wheels touch. Whenever possible utilise whatever into-wind distance you can use - i.e. across the runway, ground steering across wind when firmly on the ground. Cross-wind landings up to 8 knots should present no real problems, but exercise great care in stronger conditions, and because of the high torsional loads which can be imparted to the trike upright tube and wing keel tube, always carry out detailed inspection after every cross-wind landing.

Ground Handling (see additional note sloping fields, page 13A)

Flex wing microlights are unique in their ground handling ability. In winds over 5 knots, always turn the aircraft until one wing is resting on the ground which will help stabilise the craft until you are ready for flight. A ground picket or weight (fuel can or similar) is very useful to tie the wing tip to in order to prevent damage to the tip and to hold the wing steady. When taxiing cross wind do not make the mistake of letting the up-wind wing go down as this will greatly increase the chances of the craft blowing over. Instead, try to hold the wings dead level as this will present the minimum obstruction to the cross wind. When taxiing down wind, push the bar out to prevent the wind getting under the sail and putting you out of control.

Flying

Trike flying is pure flying. Never before has there been such a simple-to-fly craft which is so efficient. Its simplicity can be deceptive, and just as you are sitting back enjoying yourself, things can go wrong. Engine failure is the main problem and in general there are two main reasons : fuel or ignition.

Frequent inspection and maintenance is the only path to enjoyable flying. Always fly within easy reach of landing fields, and beware of the temptation to show off in front of friends and spectators. So many good and experienced pilots have been killed doing just that. Fly sensibly, for fun, and with care, your Gemini Flash will give you many hours of pleasurable flying.

Additional Notes - AEROBATIC MANOEUVRES & STALL CHARACTERISTICS.Stall Recognition

Pilot flight instruction manuals will clearly define all aspects of stall behaviour and the Flash stalls just like any other aircraft. Stalls within the flight envelope are perfectly safe to demonstrate providing you have sufficient altitude - minimum 1,000' - and the correct entry and recovery techniques are used. To demonstrate the stall, the bar is slowly pushed away and the airspeed allowed to decay at about 1 mile per second. At around 35 MPH the aircraft will feel heavy to roll and very sluggish. It will be descending and you will feel quite high back pressure on the control bar as the wing attempts to automatically pitch its nose down to recover airspeed. This is the incipient stage of the stall and to recover, simply allow the bar to return to a neutral position and the aircraft will pitch down slightly and increase air speed. If you continue to push the bar out, the back pressure will increase and at around 26/30 MPH (dependant on load) the wing will stall resulting in very high back pressure and immediate nose drop. Hold the bar out slightly until airspeed starts to increase and then return it to neutral position. Very smooth air conditions, clean piloting techniques and light cockpit loadings may make the wing difficult to stall. It may stabilise in the incipient stall state and simply "mush" descending quite rapidly at a low airspeed but not actually stalling and pitching down. Simply recover as for an incipient stall. Be aware of the reversing pressure forward and rearward on the control bar as the nose drops and as airspeed is increased.

Whipstalls

A whipstall is defined as a stall break induced from an angle above 30°. At the stall break the wing will pitch sharply down and accelerate rapidly. The steeper the entry to this break, the steeper the subsequent dive and a high whipstall where airspeed decays significantly can lead to an irrecoverable situation. If the wing loses all airspeed at a high angle of attack, the nose drops sharply and it accelerates down and forwards. It can easily fly around the mass of the trike unit and occupants, completely inverting the aircraft. WHIPSTALLS ARE EXTREMELY DANGEROUS. If a whipstall is entered by accident or careless piloting, under no circumstances must the control bar be pulled back at the break or immediately after the nose pitch down recovery has begun. Action of this kind may make a survivable whipstall into an unsurvivable one. The correct approach is to hold a bar out past the neutral position until the airspeed has built up holding off the back pressure caused as the nose rotates down. Be ready for a very high forward pressure as the airspeed goes up and the wing starts to recover. There is a high chance of a second and steeper whipstall being entered at the recovery from the first and one way to prevent this is to bank the aircraft as the speed starts to rapidly decay after recovery. This will put you into a high speed turn from which you should be able to recover normal flight.

Wingovers

This manoeuvre is again prohibited and extremely dangerous. A wingover is entered by diving the aircraft and as it climbs, applying high bank at the top. It may be used to avoid a whipstall but the pilot should not be in that situation in the first place. The high energy retention of the Flash and strong pendular effect can result in the trike unit being swung up and around the wing past the vertical and almost into an inverted spiral. Since this situation only occurs at the top of a steep climb, airspeed is obviously lost and the aircraft can invert. This extremely hazardous situation can also result from a high bank turn which is rapidly

reversed IE entering a steep say left hand 360° turn from a steep right hand one. At the cross over between the two turns the trike unit is accelerated and can induce a far higher bank angle than that required or anticipated by the pilot.

INVERTED FLEWINGS DO NOT FLY. THE TRIKE UNIT WILL FALL INTO THE SAIL AND SEVERE STRUCTURAL DAMAGE WILL RESULT.

High Speed Stall

The stall speed increases as the load increases. A manoeuvre which induces " g " loadings (60° bank turn = 2g) will also increase the stall speed. If the Flash is flown in a steep bank turn and the bar is pushed out, it will lose airspeed and may enter a stall at a surprisingly high speed. During special flight tests by company test pilots a high speed stall was induced at a speed in excess of 75 MPH. A high speed stall entered during a steep turn will cause the aircraft to tighten its turn and may result in a vertical or near vertical dive.

WARNING

DO NOT EXCEED THE LIMITATIONS - 45° BANK ANGLE 30° PITCH - NON AEROBATIC

POSITIVE LOADING MUST BE SUSTAINED AT ALL TIMES

WAKE TURBULENCE

As an aircraft flies it leaves behind it severely disturbed air: Avoid flying, taking off or landing closely behind another aircraft, and be particularly careful of flying into your own wake turbulence. It is very easy to fly into your own wake during 360° turns and the effect can be quite violent. Microlights have been rolled as much as 90° turns by flying into their own wake. If you already happen to be in a bank, the potential results are self evident. Wake turbulence is greatest at high G loadings, during turns or slow flight.

Ground Handling - Sloping Fields

The Gemini is very stable, but be aware that the wing high above your head can affect the stability, particularly on sloping ground.

RIGGING

Page 14.

Wing

1. Select a clean, dry area and lay the wing down, opening the zip to reveal the control frame and underside of the wing.
2. Open out the control frame and attach the corner joint.
3. Lift the wing from the front and rotate it so that the wing is now laying on the ground with the assembled control frame flat on the ground underneath.
4. Remove all the sail ties and open each wing about a metre. Lift the kingpost and, checking to ensure the wires are untangled, fit it into the nylon apex block through the hole in the top surface of the sail.
5. Tension the rear fin wire over centre lever, ensuring that it clips down tightly.
6. Open the wing in stages, one wing at a time to prevent damage to the cross tube joints.
7. Ensure that all wires are untangled and free from twist, particularly at the connections. Locate the cross tube tensioner cord and pull back as if to rig the wing, but do not attach the tangs, allowing the wing to relax in a fully-open position.
8. Fit the battens starting with the in-board main battens and working out-board towards the tip. Do not force the battens if they seem hard to push fully home. Fit the double cords by hooking one loop in place and then pulling the other loop over, if necessary using the special batten hook provided. Once the main battens are in place and tensioned, fit the intermediate battens by locating the pocket with the batten upside down (camber to bottom) and then rotating it over the correct way (camber to top) and sliding it fully into the pocket. Sometimes it may be easier to leave difficult battens until the cross tube tension is applied. You may then find them easier to push fully home.
9. The undersurface battens are also cambered but the camber is reversed towards the top battens. They are inserted by lifting the trailing edge and locating the pocket, pushing the batten fully into the pocket until it locates on the front side of the leading edge.
10. Finally, fit the nose batten in place, locking it behind the nut and the nose plate and seal back the Velcro nose cone.
11. When all the battens are in place and tensioned, the main cross tube tension can be pulled on with the cord inside the rear fin. As the two wires are pulled back, locate the rear tang onto the location pin following with the front tang. Allow the tension cord to retract slowly and fit the pins with safety rings to prevent the tangs releasing.
12. Locate the tip sticks into the sockets, ensuring they are firmly down to the limit.
13. Raise the control frame by lifting the nose of the glider until the wing can be rocked back against the base bar, raising the control frame and allowing the nose wire catch to be fitted and pinned. This operation is helped by having a helper lift the keel at the rear at the same time as you lift the nose, both of you rocking the wing back over the control frame base bar. In light winds the nose can be lowered and the wing allowed to rest on the nose and control frame whilst the full pre-flight rigging check is carried out. In turbulence or strong winds it is best to have a helper hold the wings level at the nose whilst these checks are carried out.

Trike

14. Detach the transit and strut ties and roll the trike unit into position from the rear of the wing, fix the main hang bolt and back-up wire bolt, ensuring that the locking pins or rings are fitted through the bolts to prevent loss of the wing nuts.
15. Put the trike propeller horizontal (or one blade downwards for a 3-blade propeller) and lift the nose of the wing until the keel tube rests on the propeller hub. Lift the wing from the control frame base levering against the propeller hub until the folded seat of the trike unit can be locked down. This operation must be carried out with care and it helps to have a helper preventing the trike from rolling backwards, (wheel chocks are useful). Your helper can also push the trike vertical strut backwards which relieves some of the weight. Fit the front strut in place and pin the telescopic seat struts with the 'R' clips. Carry out a full pre-flight rigging check as the check list.

FUEL

After rigging the trike, fill up with the correct grade of fuel; the fuel is the life blood of the trike, treat it with respect and never fill up using dirty funnels or tubes. Do not put the petrol cap or filler cap on the floor as this can pick up dirt, and watch that dust does not fall into the fuel tank. The fuel should be filtered both when you fill up your mobile container and also as you pour it into the trike fuel tanks. A tiny particle of dirt can clog a jet and cause a serious accident. Observe strict fire precautions and do not allow anyone to smoke. Be polite at all times, but be as impolite to smoking spectators as you need to be to prevent a fire hazard. Fully inspect all fuel lines and periodically replace the fuel filter. On most models there is also a filter attached inside the fuel tank, and this too may need cleaning. Wipe down all fuel spills and fasten all containers tightly as soon as you have used them. Remove all spare fuel containers away from the immediate area and away from spectators.

FUEL TAP

A 3-way fuel tap is provided. The quick-release fuel connectors are self-sealing. Be careful not to take off with the fuel tap closed. An extended full power check prior to take-off will ensure that the fuel system is working OK.

LOCKING NUTS

Major critical nuts are wire locked but you must always check all lock nuts to ensure they are not coming loose.

DE-RIGGING

De-rigging is an exact reversal of the rigging procedure, but great care must be taken when rolling up the sail to ensure creases are kept to a minimum. Always use the special padding pads to prevent the wing structure from damaging the sail at the control frame, trike hang block assembly and kingpost assembly. At least 4 sail ties are needed to hold a de-rigged glider firmly and these should be positioned as the rolled glider is lying on the assembled control frame. At this stage the bag can be fitted so that as the wing is rolled over to dis-assemble the frame, the bag is underneath protecting the wing and can be zipped up after the control frame has been folded. Hold the control frame with sail ties.

RIGGING AND DE-RIGGING INSPECTION

As you rig your wing you should be meticulous in your inspection of each component. This is the best time to see potential faults which may be missed when the aircraft is fully rigged.

RIGGING AND DE-RIGGING INSPECTION CONTINUED

Never allow yourself to be distracted during assembly of your aircraft and always rig to a repeatable sequence. Do not rely on the pre-flight check to find faults, but look carefully at all aspects of your aircraft as you put it together. After flight, and particularly if you have had a heavy landing or suspect damage may have occurred through ground handling or cross wind landings, you must inspect the aircraft thoroughly. Wires should be checked for damage and fatigue, tubes for bends or dents and the sail for tears or abrasions. Please check the maintenance and repair section in this manual.

NEW AIRCRAFT

ALL NEW AIRCRAFT ARE FLOWN AND SET UP BY EITHER THE FACTORY OR BY APPOINTED AGENTS. PRIOR TO DELIVERY TO THE CUSTOMER, A FULL CHECK FLIGHT IS CARRIED OUT AND ADJUSTMENTS MADE TO THE WING TO ENSURE IT FLIES HANDS OFF AT THE RIGHT SPEED AND IS PROPERLY TRIMMED OUT. OWNERS ARE DISCOURAGED FROM MAKING ANY ADJUSTMENTS AND IF YOU FEEL YOUR NEW GEMINI FLASH IS NOT PERFORMING AS IT SHOULD, IT IS ESSENTIAL THAT IT IS RETURNED TO THE FACTORY OR TO THE DEALER FOR CHECKING.

THE FOLLOWING NOTES ARE FOR GUIDANCE ONLY AND SINCE TUNING OF FLEX WINGS IS A COMPLICATED AND EXACTING SCIENCE, NO ADJUSTMENT SHOULD BE MADE WITHOUT A FULL UNDERSTANDING OF THE PRINCIPLES INVOLVED.

Wing Trim

All Mainair wings are test flown before delivery to the customer; however, all flex-wings settle down after a few hours flying and the trim of the wing may change slightly. If the trim of a wing changes, either shown up as a change of speed, or for the wing to have a tendency to turn on one direction, check the following before jumping to any conclusions:

Make sure that the battens are in the correct side of the wing, that is battens with red plastic end caps fitted to the left-hand side of the wing, and battens fitted with green end caps to the right-hand side of the wing. During pre-delivery test flying, small adjustments may have been made to the shape of the individual battens and it is recommended that any changes from the standard shape is noted on the batten profile by drawing the actual shape of the battens in red ink on the batten profile pattern in order to record the changes from standard. It is for this reason that it is imperative that battens are installed on the correct side of the wing.

Any changes in the trim or handling characteristics of a wing due to settling down should be only very slight and occur gradually over a period of time. If a wing which has been flying correctly suddenly develops a turn or changes its trim speed, it is most likely that some damage has occurred. It may be nothing more than the shape of the battens having been changed in transit, so first check the battens against the batten profile. If a wing is damaged, it should be returned to the factory or the nearest dealer for safety checks before it is flown again.

Having carried out the checks above, if it is found necessary to adjust the trim speed of the wing, proceed as follows:

Refer to page 29. The position of the hang point on the keel can be adjusted by moving it towards the front of the keel to increase the speed and towards the aft of the keel to reduce the trim speed. The adjustment is made by removing the hexagon socket bolt with the 5mm key which will be found in the wing tool pocket in the batten bag. Remove the bolt and move the hang block to the new position; relocate the bolt - DO NOT OVERTIGHTEN. You should aim for a hands-off trim speed of approximately 50-55 mph indicated.

If the required trim speed can not be achieved by adjusting the hang point alone, then adjustments can be made to the leech line settings. Proceed as follows: Refer to pages 28 and 30 being careful to use the correct adjustments for a Flash I, Flash II, or Flash II Alpha.

IMPORTANT: ADJUST ONLY ONE LEECH LINE AT A TIME MOVING IT ONLY ONE HOLE AT A TIME ON THE ADJUSTER AND CHECK FLIGHT THE AIRCRAFT FOLLOWING EACH ADJUSTMENT.

First adjust the inboard leech line moving it up to reduce speed and down to increase speed on the adjuster. If the desired trim speed can not be achieved after moving the inboard leech line two holes, then the next adjustment should be to move the intermediate leech lines in the appropriate direction, namely, up to reduce speed and down to increase speed.

The foregoing should provide adequate adjustment to bring the aircraft to the desired trim speed. If, after these adjustments, the wing is flying too slow, check that the cords holding the battens in place are tight, particularly the cords pulling back the undersurface near the tip in the case of a Flash II or a Flash II Alpha. The cord should be so tight as to require levering into position using the batten cord rigging tool supplied with the wing tool kit.

If the foregoing does not achieve the desired trim speed of approximately 50 to 55 mph, adjust nothing else but contact your nearest Mainair dealer.

Adjustments to correct for inherent turn

All new Mainair aircraft are check flown and adjusted by the dealer, and should fly straight in cruising flight mode.

Note: It is normal for your aircraft to have a very slight turn when operating at very high power settings due to propeller torque reaction.

After a settling in period of several hours flying, your wing may develop a tendency to turn slightly in one direction or the other, and while this is in no way dangerous, it can be a nuisance on long, cross country flights, rather like driving a car with incorrectly balanced tyre pressures.

To adjust the wing to correct for inherent turns, proceed as follows:

First check the battens against the batten profile - bearing in mind that during the initial flight test small adjustments may have been made to the batten profile and these should be noted on the batten profile pattern.

Next, if your wing is fitted with button pin index adjustments, check that the button pin is properly located in the neutral position (marked N) on both wing tips.

Next, if there is the slightest possibility that the wing has been damaged, a full airframe check must be carried out, paying particular attention to make sure that the leading edges are straight when they are de-rigged and relaxed.

Having carried out the above checks and the wing is still turning, for example, to the right, then an adjustment can be made to the left-hand button pin index adjuster. To carry out this adjustment, the wing should be de-rigged so that the sail tension is relaxed, the spring button pin can now be depressed and the wing tip rotated to the next hole in the UP position, that is the direction which will lift the trailing edge on the wing which is being adjusted. IT IS IMPORTANT THAT THE ADJUSTMENT IS MADE ONE HOLE AT A TIME AND THEN A CHECK FLIGHT CARRIED OUT BEFORE FURTHER ADJUSTMENTS.

For a left-hand turn, the adjustment should be made by moving the right-hand wing index up one hole.

If the foregoing does not correct the problem, contact your nearest Mainair dealer.

RUNNING IN AND STARTING UPRUNNING IN ON ROTAX ENGINES

The Rotax engine has a detailed running in schedule in the engine manual which allows you to run the engine in over a very short time. Secure the trike safely since it is necessary to have the propeller fitted during all running in. Follow the suggested running in times precisely.

STARTING UP

A trike is a lethal machine. A spinning propeller can be all but invisible and there have been countless accidents; don't think it cannot happen to you! Locate the front wheel against something immovable such as a wall, being aware that as soon as the engine starts there is propulsion and the trike will want to move. Clear all spectators away, particularly away from the area which would be affected by a fractured propeller. In practice, this means that everyone should be in front of the trike, but well clear at each side. Select a member of your crew to keep people away - as they tend to drift closer and you may be too busy to notice them. Check to make sure there is nothing that could be sucked into the propeller, such as seat belts, scarves, cleaning cloths, maps, clothing, etc., etc. Switch on the fuel and seat yourself in the trike. Open the hand throttle about 1/8 and select around half choke. These amounts will vary with the machine and you will need to experiment a little. **BE AWARE OF THE DANGER OF STARTING UP WITH THE HAND THROTTLE OPEN TOO FAR.**

Switch on the ignition, calling loudly "Switches on". Get hold of the pull start or electric ignition switch, and before turning the engine at all, look around and shout "Clear prop". Do not feel embarrassed or self-conscious, you are starting an aeroplane and it's a serious business. Calling these warnings should be a habit. If all is clear, start up. Continue to check for drifting spectators and run the engine until it is warm and runs smoothly without choke. If the engine does not start after a few pulls, it's likely to be flooded and it will be necessary to remove the plugs, clean and dry them, and start again.

GENERAL MAINTENANCE

WE RECOMMEND THAT REPAIRS OR REPLACEMENT OF PRIMARY AND SECONDARY COMPONENTS IS CARRIED OUT AT AN APPROVED MICROLIGHT FACILITY.

The essence of enjoyable triking is maintenance. Launching and landing in fields and open spaces, which are often bumpy and rough, subject both your trike and glider to the most appalling loads, and it is inevitable that things will go wrong. Vibration caused by the 2-stroke engine can fracture components and vigilant inspection is essential. Every flight should be preceded by a full pre-flight check and any noticeable failures or potential failures should be rectified before flight.

It is essential to grease all three wheels and to keep the tyres correctly inflated. The control cables should be graphited occasionally, but removing all accumulated dust from them is essential. As they operate, they wear out and this dust will one day jam them unless they are kept clean. A frequent strip down to inspect the nipples and joints is good practice.

You must pay particular attention to the exhaust system and its mountings. Frequently inspect for stress induced fractures and have these repaired as soon as they become evident. Carefully check the rubber mountings and replace any that show signs of fatigue.

Inspect all rubber engine mountings and the whole engine mounting assembly on a daily basis. Get used to frequently going over the whole trike checking cables for stretch and elongation, aluminium plates and channels for worn holes and loose fitting bolts, and the general integrity of the trike structure itself. Also keep an eye on such obvious things as the seat and harness straps.

Ensure that the fuel tank is strapped tightly in place at all times, and inspect to ensure that no chaffing is taking place. Inspect and frequently clean out or replace the fuel line filters and in addition, wash out the air filters from time to time. Ensure that all cable runs are straight and free from damage and carefully inspect the electrical ignition system.

Remember, preventative maintenance is the only way to trouble free and pleasurable trike flying. Please refer to maintenance schedules.

PROPELLER CARE - See also page 17 - 3 Blade option.

Wooden propellers need careful handling if they are to perform well for you. Avoid using your trike on dusty, stoney ground, or anywhere where abrasive materials are sucked through the prop. The leading edges of the propeller can be protected with high-impact helicopter rotor tape. If this eventually shows signs of looseness it should be replaced. It has been proved that wooden propellers go out of balance with time. Moisture absorption is the problem, and it can be reduced by thoughtful handling. Always store the trike unit with the blade in the horizontal position in a warm dry place and maintain the high quality varnish finish. Frequently

CONT:-

PROPELLER CARE CONTINUED

check and rebalance the propeller if required. There are many publications and articles available on propeller maintenance. You are advised to locate and read them.

FUEL SYSTEM - see drawing ON PAGE No 27 A

ELECTRICAL SYSTEM - see drawing ON PAGE No 26

SPARE PARTS ORDERING - Please order by quoting reference number in illustrated parts catalogue, giving full part description and trike or wing serial number

MAINTENANCE AND REPAIR

WARNING - THE FLASH WING AIRFRAME IS DECEPTIVELY SIMPLE, BUT LIKE ALL AIRCRAFT REQUIRES SKILLED AND QUALIFIED ATTENTION. WE DO NOT RECOMMEND SELF REPAIR OR RE-ASSEMBLY BY OTHER THAN FACTORY NOMINATED REPAIR AGENTS. NO REPLACEMENT PARTS SHOULD BE FITTED UNLESS THEY ARE FACTORY SUPPLIED AND IDENTIFIED SINCE THE WHOLE WING STRUCTURE IS CLASSIFIED AS PRIMARY STRUCTURE.

FABRIC

Care and maintenance starts the very moment you take delivery of your wing. 50% of all damage and degradation of your wing will take place when it is being stored or transported. Packing away properly is the most important single thing you can do to extend the life, efficiency and safety of this fragile piece of high technology. Dumping it in the bag with a few ties round it is the fastest way to rub holes in the sail, abrade rigging cable and dent tube. Despite the best care you can take, you will still have accidents with the odd wall or wire fence or your protection pads may slip and you will be faced with slight damage to the fabric. Where this takes place depends on how it can be repaired, high load areas such as a trailing edge being critical. Any cuts or tears through the trailing edge, sail fixing points or similar high load areas must be repaired at an approved workshop. Small damage to panels, leading edge cover etc can be repaired with self adhesive tape which is cut to size, pressed into place on the dry clean sail and warmed gently with a hair dryer to melt the adhesive, being careful not to apply too much heat. We define small damage as abraded holes no more than 15mm dia and small cuts no longer than 20mm. Anything larger should be inspected by a qualified engineer.

STITCHING DAMAGE

All the seams are firstly joined with a double sided sail adhesive tape and then double zig zag sewn. Thread damage never ever gets better and eventually runs. Since the wing is held together with stitches, its pretty obvious what will happen when the stitching fails. If you abrade a seam, then have the damage repaired before it gets worse. Small non loaded areas can often be repaired in-situ by the tedious but effective method of hand sewing back through the original stitch holes. Never use anything but matching polyester thread which is available from Mainair Sports or any good workshop or sail makers.

CLEANING

The best answer to dirty sails is to keep them clean, but if all else fails and you need to wash your wing, then select a dry day and have access to a good hose and clean water supply. Never use strong soaps or detergents since soap residue can re-act with ultra violet light and degrade your fabric. We recommend a very mild liquid soap (washing up liquid) and a soft sponge. Gently wash the fully rigged wing, frequently hosing clean. Copious amounts of clean water will not harm the wing and can be very beneficial in removing sand and grit which may get trapped inside the leading edge pocket usually in the nose or wing tip areas. Ensure the wing is completely dry before de-rigging.

ULTRAVIOLET DEGRADATION.

The sail is made from 100% Polyester fabric which, like all similar materials, is subject to degradation caused by exposure to sunlight. The fabric is treated with a special UV resister and in normal use the sunlight has little effect even over many years. Extreme conditions can have a disastrous effect. Leaving your aircraft rigged in, say, hot desert conditions for 6 months or so will result in complete breakdown of the fabric. Never leave your aircraft in sunlight for longer than is necessary, and check the condition of the mostly effected top surface against the protected under surface at intervals.

TUBES

The rules applied to the fabric also apply to the aluminium airframe. Care and consideration in de-rigging and transportation will pay huge dividends in airframe life. Any damage to one of the structural members is serious and can usually only be repaired by replacement. Tubes suffer from abrasion or indentation the first accelerating fatigue fracture and the second reducing the strength of the part by a massive amount. If you bend, dent or damage the tubular members in any way, seek immediate professional advice before flying again and have replacement parts fitted.

BOLTS and NUTS

All the bolts are AN series airframe bolts and only these type should be used for replacement. Any bolt which is bent or showing signs of corrosion should be immediately replaced. Nyloc nuts should only be used once and wire locked nuts must be re-locked in place.

RIGGING WIRES

The main danger with the rigging lies in kinking the wire, again caused by bad de-rigging. Once a wire has a kink, the strands are damaged and replacement is the only cure. The side wires are particularly important and should receive a frequent detailed inspection. Check for wire damage along the length but the main failure area lies immediately adjacent to the swaged fitting. Look carefully for signs of strand fracture at this position. Corrosion is a serious problem particularly in coastal areas and shows itself as a white powdery deposit. Corrosion cannot be cured and replacement is the only answer.

FITTINGS

Most fittings on the Gemini Flash are manufactured from aluminium alloy and then anodised. damage can occur through scratching or by the stress of an unduly heavy landing or crash, or by general wear. Look for elongated holes and stress lines on the aluminium. Damaged items should be replaced.

BATTENS

Battens form the wing shape and hence dictate the whole performance of the wing. They need treating with care, and since they are subject to constant tension both during flight and rigging, tend to lose their shape and flatten out. It is essential that they are reformed at frequent intervals and checked against the template. The best way to reform is to hold the batten against your knee and, whilst applying pressure to bow the batten, slide it side to side over the area you want to bend. Direct point bending will usually result in either a poor shape or a broken batten.

Refer to trimming notes.

CARE and CLEANING

Microlights operate from fields, beaches etc, and are submit to contamination from salt and water on beaches and mud and manure on fields. We recommend that your machine is cleaned thoroughly after every day's use, particularly if used on the beach or near salt water conditions.

SALT WATER OR BEACH CONDITIONS

After each day it is essential that you hose off your machine completely with fresh, clean water. Pay particular attention to areas where sand can lodge such as between the axle plates and under small brackets and fittings. It is important to ensure that all tubes are plugged to prevent the ingress of salt water, but if you suspect that this may have happened, it is essential to remove these plugs and wash out any contamination. Salt water will corrode aluminium at an alarming rate.

WHEELS

If the wheel bearing has been immersed in salt water it will be necessary to remove the wheel, clean away the old lubricant and re-lubricate.

FIELDS

Mud and manure must be hosed off as soon as possible, since not only can it hide defects, but it can also contain corroding elements. A strong hose down with clean water is recommended, again paying particular attention to areas between plates and fittings.

BATTEN END FINGERS

Continual rigging and de-rigging may lead to the white nylon batten end finger wearing to a very sharp edge. Please note that this may cut through the sail stitching in the batten pocket and from time to time the sharp edge should be filed off to a smooth radius.

3 BLADED PROPELLORS.

The 3 bladed propeller option for our aircraft offers a reduced vibration, better economy and improved performance. Care and maintenance is exactly the same as for the standard wooden 2 blade propellers. Keep the unit in balance, use leading edge tape for protection and store carefully.

BLADE ADJUSTMENT.

Each blade is ground adjustable and is infinitely variable. It is held in a nylon saddle arrangement and secured with 6 bolts. These bolts must be tightened evenly and checked from time to time. About 14 ft/lbs is a reasonable torque setting but wood expands and contracts with moisture and it is wise to check these bolts frequently.

Adjusting pitch is achieved by rotating the blade and checking the angle very carefully. Quarter of a degree will make a 100 - 200 rpm difference so as you can see it is very critical. We have standardised on a position along the blade 12" from the hub centre and use the Mainair propeller setting jig and protractor to check the angle. This angle is critical for the behaviour of the propeller and to meet the noise requirements for the U.K.

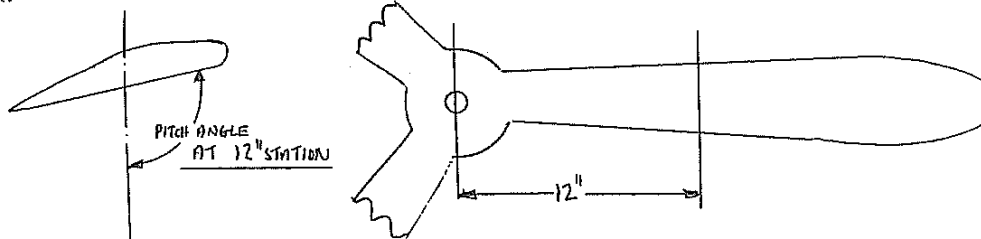
GEMINI FLASH, FLASH 2, FLASH 2A

Engine 503 - 62" dia. - Pitch Angle 107° - Meets U.K. Noise regulations 1987.
Engine 462 - 62" dia. - Pitch Angle 107° - Meets U.K. Noise regulations 1987.

This position is also best to give all round economy and performance. DO NOT SET THE PROPELLOR AT A DIFFERENT PITCH OR YOU WILL INVALIDATE YOUR PERMIT TO FLY AND NOISE TYPE CERTIFICATE.

OPERATION OVERSEAS (Applicable to foreign registered aircraft only. Aircraft registered in UK must comply with pitch settings given above when operating overseas)

Varying climatic conditions or altitude operation may benefit from adjusting the propeller to a different setting from that above. The finer the pitch, the faster the engine will be able to turn the propeller and in general the more thrust will be developed. However, the noise level will increase and the fuel consumption increase. You must be careful to match the pitch to the engine RPM such that it is impossible to exceed the engine limiting speed as detailed in the manual even at VNE. Increasing pitch will tend to reduce thrust but will not necessarily improve fuel consumption. In addition, too much pitch may cause overheating and damage. If the engine speed is held down such that it cannot develop its full potential, the power produced will be low and the propeller will prevent the tuned exhaust system functioning properly, leading to speed fluctuation.

METHOD FOR PITCH SETTING

Start with two blades tightened and slacken all 6 bolts on the blade to be adjusted, which should be vertical. Grasp the blade and flex it carefully backwards and forwards with one hand applying a twisting force near the hub with the other hand. If you find you cannot adjust it, you can slacken off the bolts of the adjacent blades. Continually check with the setting jig and protractor. When satisfied it is correct, tighten up all 6 bolts and re-check. Repeat as required. Remember, it is most important to set all 3 blades at exactly the same pitch angle. If the nylac nuts loose their locking ability from repeated assembly and dis-assembly they should be replaced.

Assembly Instructions for your Adjustable Pitch Propeller

First, let's check and see if we have all the parts

1. Propeller Blades 3
2. Nylon Retainers 2 for each blade
3. Aluminum Plates 2 for each prop assy.
4. Bolts with flat washer and safety nut 4 for each blade

Pick up one of the aluminum plates. You will notice that one side looks as though it has been machined and is much more pleasant to look at. This is the side of both plates that you want showing on the outside of your assembled prop. First, insert all 12 bolts through the plate from the "Pretty side." Leave the 6 center holes empty. Lay the plate down on a flat surface with the bolt ends (threads) sticking up. Take one of the nylon retainers and with the cupped side up and the open end facing outward, press it down onto one of the groups of 4 bolts. Now do the same for the other two retainers.

Next lay the butt ends of the prop blades down in the retainers.

Note.

lay the blades down with the flat side up.

Press the remaining 3 retainer cups down onto the others which are holding the blades.

With the pretty side up, press the other plate onto the bolts. Put the washers and then the nuts on the bolts and finger tighten them.

After adjusting the pitch, tighten the nuts

Blade Adjustment
Each blade is ground adjustable and is infinitely variable. It is held in a nylon saddle and secured with 6 bolts which must be tightened evenly and checked from time to time. The bolts should be torqued to 14 ft/lbs.

To adjust the pitch slacken all 6 bolts on the blade to be adjusted which should be vertical. Grasp the blade and flex it carefully backwards and forwards with one hand applying a twisting force near the hub with the other. Continually check with the setting jig and protractor and when satisfied it is correct, tighten up all 6 bolts and recheck. Repeat as required. Remember, it is important to set the blades at exactly the same pitch angle. $\frac{1}{4}^{\circ}$ will make a 100-200 rpm difference, so you can see it is very critical.

The Mainair propeller setting jig and protractor is the tool which should be used, and we have standardized on a position 12" from the centre of the hub. If the NYDC nuts lose their locking ability from repeated assembly and disassembly they should be replaced.

Section 'S' approval We have CAA approval for use of a 3-blade propeller on Gemini Flash 462 and 503 engines. Please refer to the pilot manual, before assembly or operation. Propeller Balancing.

Multi blade propellers are best balanced on a suspension balancing tool. This accessory is available from Mainair Sports.

Rigging Aircraft.

The greater hub diameter necessitates a different rigging technique. Firstly set the propeller one blade down whilst lifting the nose of the wing and rolling the strike unit backwards. Before completing the lift, the wing keel should be moved over to one side rotating the propeller one blade vertical and alongside the fin. This allows the wing keel to drop down the side of the hub giving the necessary clearance between the control frame and cockpit nose. Take care whilst lifting not to damage the blade on the wing trailing edge during rigging and de-rigging. The wing keel must also be protected from damage by fitting a protection pad to the hub whilst rigging.

Wherever possible use a helper when rigging and always check the rear wheels.

Hub Marking for pre-flight inspection

It is a C.A.A. requirement that each blade be marked next to the hub so that any slippage can be easily identified. This is best achieved by marking between the split line of the retainer, using either a fine paint brush and paint or an indelible ink marker. Whenever the propeller is dis-assembled for overhaul; re-warmishing or blade replacement, any existing marks must be removed and the unit re-marked after final adjustment.

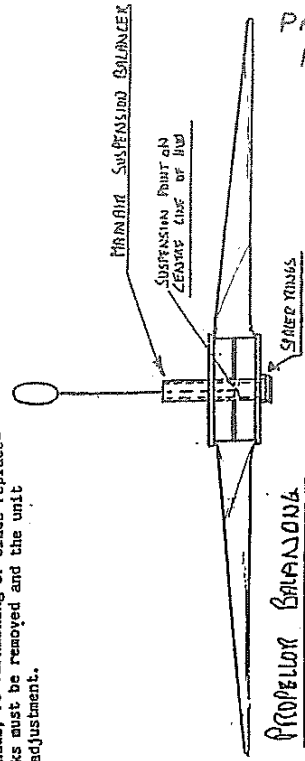
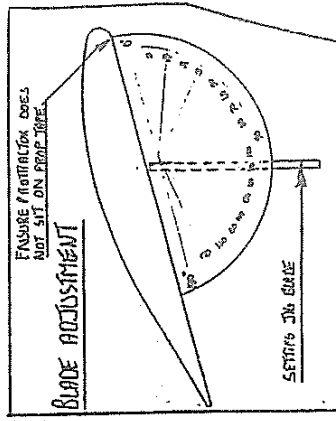
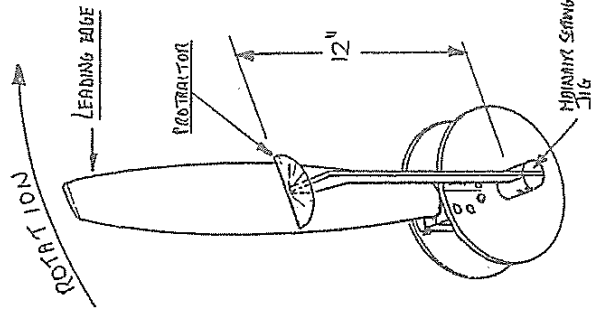

PROPPELLER BALANCING

AN 5-31
AN 5-34
THROUGH HUB
TORQUE TO 14 LB/FT

AIRFRAME LIFE AND MAINTENANCE SCHEDULE

The whole concept of the flex wing microlight revolves around the ability of the wing to distort and change shape to accommodate the flight loads and to be controllable in flight. The airframe is designed to be non-rigid, and designed strongly enough to be able to flex in this way for the lifetime of the aircraft. However, "lifetime" is very subjective and is being constantly extended as microlight development catches up with materials and operational limitations. Not very long ago "lifetime" was often under 100 hours, whereas today (1985) 300-hour airframes can easily be found. Very few aircraft have over 500 hours, but they are around. No doubt in 2 years we will know of airframes with over 1,000 hours, but the reality of today is that, despite tests, experience and calculation, no-one quite knows how well the various components will stand up to the constant flexure, vibration and atmospheric corrosion the airframe is subjected to throughout its life. Constant cyclic loading causes fatigue, and fatigue shows itself as hairline cracks and fractures. Fatigue can be greatly accelerated by vibration which can result from poor propeller balance, or by poor flying techniques.

As a result the following table is advisory only and based upon calculation and experience.

MAINTENANCE SCHEDULE The X hours are for private owner operation only. Training and commercially operated aircraft must follow the 0 hours.

Note

A full visual inspection must be carried out each time you rig and de-rig. Additional full checks must be carried out at any time you suspect damage may have occurred ie heavy landings, transit damage etc.

Key - see maintenance and repair section of this manual.

Inspection - visually inspect, checking for loose fittings, hole elongation etc.

Major Inspection - strip part and inspect all fittings and bolts. Replace bolts as required. Test for fatigue cracks at suspect areas. Do not re-use nyloc nuts.

Replace - mandatory life of component. Wear or damage may dictate earlier replacement.

Hours - means designated work should be carried out at each period.

<u>WING</u>	EVERY	10 HRS	50 HRS	100 HRS	250 HRS	500 HRS	1000 HRS	As reqd.
<u>Battens</u>	- check shape	X						
<u>Keel</u>	- inspection	X						
	- major inspection			X				
	- replace				0 = 400hrs	X		
<u>Leading Edges</u>	- inspection	X						
	- major inspection				X			
	- replace					0 = 750hrs	X	
<u>Cross Tubes</u>	- inspection	X						
	- major inspection				X			
	- replace							X
<u>Control Frame Tubes</u>	- inspection	X						
	- major inspection				X			
	- replace							X
<u>Fin Tube</u>	- inspection	X						
	- major inspection				X			
	- replace							X
<u>Tip Struts</u>	- inspection	X						
	- major inspection				X			
	- replace							X
<u>Trike Hang Strap</u>	- inspection	X						
	- replace				X			
<u>Trike Hang Bolts</u>	- replacement			X				
<u>Cross Tube Leading Edge Pivot Bolt</u>	- replacement			X				
<u>Cross Tube Hinge Bolt</u>	- replacement			X				
<u>All Bolts, Pins & Fixings.</u>	- replacement							X
<u>Side Rigging Lower Wires.</u>	- inspection	X						
	- replace				X			
<u>Front Rear Rigging Wire</u>	- inspection	X						
	- replace							X
<u>Cross Tube Tension Rigging</u>	- inspection	X						
	- replace				X			
<u>King Post Rigging</u>	- inspection	X						
	- replace							X
<u>Leech Line Rigging</u>	- inspection	X						
	- replace							X
<u>TRIKES</u>								
<u>Wheels</u>	- inspection	X						
	- major inspection			X				
	- replace bearings							X
	- replace tyres & tubes							X
<u>Front Fork</u>	- inspection	X						
	- grease	X						
<u>Throttle Assembly</u>	- inspection	X						
	- clean & lubricate	X						

	EVERY	10 HRS	50 HRS	100 HRS	250 HRS	500 HRS	1000 HRS	As reqd.
<u>TRIKES CONTINUED</u>								
<u>Engine Control Cables-</u>	inspection	X						
	clean & lubricate	X						
	replace			X				
<u>Carburettor Air & Fuel Filters</u>	inspection	X						
	clean	X						
	replace							X
<u>Fuel Hose</u>	replace							X
<u>Rotax Gearbox or Fuji Toothbelt.</u>	lubricate hub	X						
	change gearbox oil		X					
	inspect magnetic plug		X					
	check bolt tension	X						
	inspection	X						
	major inspection			X				
<u>Propeller</u>	inspection	X						
	revarnish & rebalance							X
<u>Exhaust</u>	inspection	X						
	replace							X
<u>Spark Plugs</u>	replace every 25 hours maximum							
<u>Ignition Switch</u>	replace							X
<u>Axle Tie Wire</u>	replace				X			
<u>Rubber Mounts</u>	replace							X
<u>Telescopic Side Struts</u>	major inspection		X					
	re-lubricate or renew							X
<u>Airframe Tubes</u>	inspection	X						
	major inspection				X			
	replace							X
<u>Trike Monopole</u>	replace				0=300hrs	X		
<u>Trike Keel</u>	replace					X		
<u>Airframe Bolts</u>	inspection	X						
	replace							X
<u>Carburettor Bowls</u>	clean	X						
<u>Carburettor</u>	major inspection			X				
<u>Engine Performance Static Thrust Check</u>	carry out whenever engine is below par or every 200 hours.							

FUEL LINE NOTE

The fuel line is a special fire resistant type and must be obtained directly from Mainair Sports Ltd. No replacement fuel line must be used unless it is factory approved.

PROPELLER HUB BOLT

Frequent removal of the propeller for maintenance may lead to wear elongation of the bolt fixing holes. Care must be taken to avoid this by always fitting the propeller and disc in the same position and carefully fitting the bolts in place. Always inspect for bolt fit prior to refitting since significant elongation of these holes may lead to propeller bolt failure.

DWG NO. 99-44-52
 WIRING FOR ROTAX
 ENGINES - TRIMES
 DATE 2-4-12-85
 SUPERCEDES 99-44-50 FOR
 ROTAX ENGINES

REF	DATE	AMENDMENT
A	20-7-86	EGT TERMINALS FROM 1 = BLACK 5 = RED TO 5 = BLACK 1 = RED

MAINAIR SPORTS LTD
 SHAWCLOUGH ROCKDALE
 LANCS - ENGLAND
 0708 65131
 TOLERANCES UNLESS STATED OTHERWISE
 GENERAL ± 0.025mm DIMETERS ± 0.05mm
 CENTRES ± 0.1mm

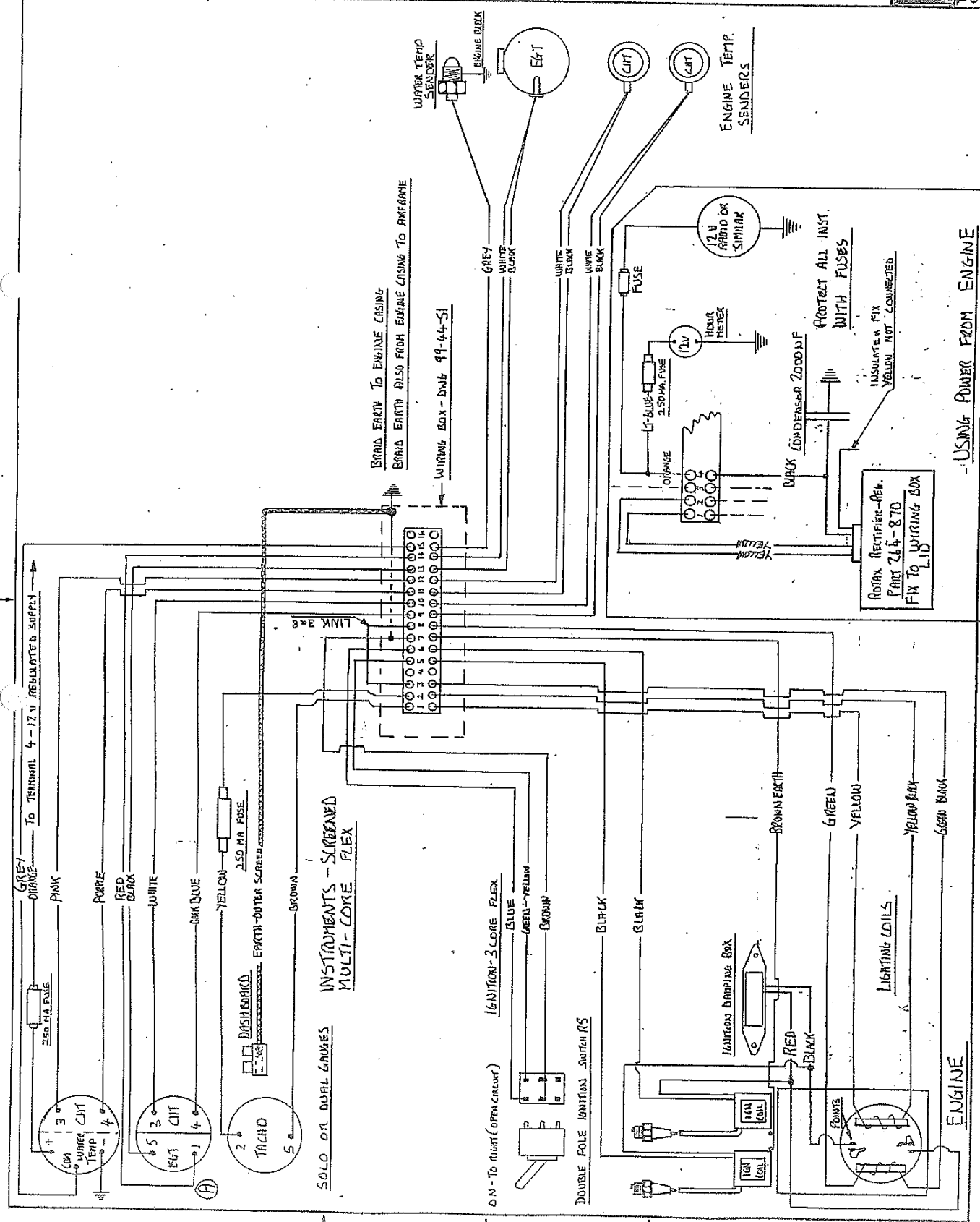

DATE 27-11-86

DWG NO. 99-00-303
 UPRIGHT ROTAX FUEL TANK LAYOUT
 DATE 12-12-85
 SUPERCEDES

REF	DATE	AMENDMENT
A	10-4-86	DUPLICATE TO SUIT ALL SPORTS (GTA) ENDS
B	7-8-86	REMOVE TANK TO STABIL ENDS DUMP VALVE STANDARD FIT FIRE PROOF FILTER AFTER AWP

MAINAIR SPORTS LTD
 SHAWCLOUGH ROCHDALE
 LANCOS - ENGLAND
 (0706 65131)
 TOLERANCES UNLESS STATED OTHERWISE
 GENERAL ± 1.0MM DIAMETERS ± 0.05MM
 CENTRES ± 0.5MM

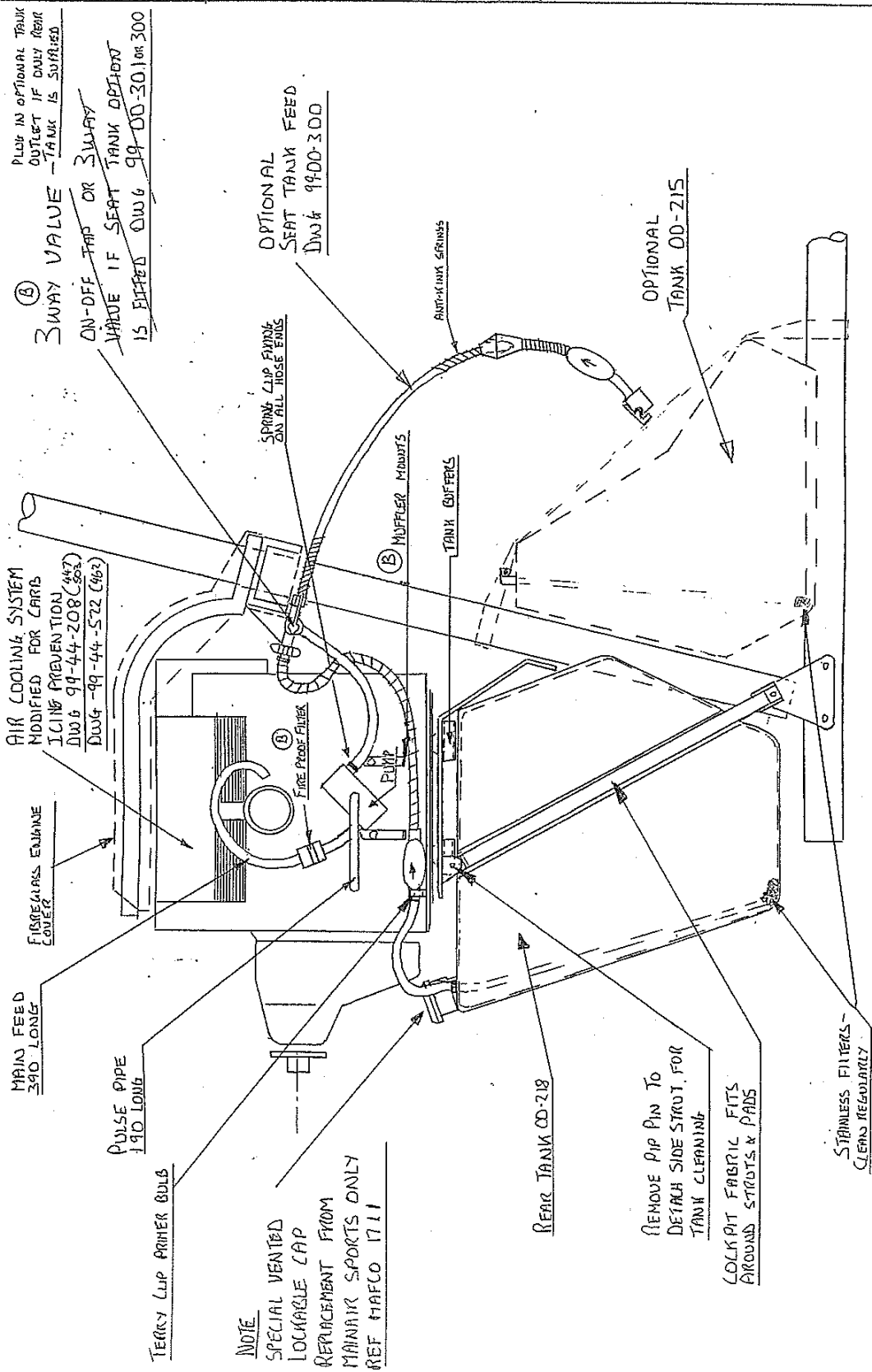

PLUS AN OPTIONAL TANK OUTLET IF ONLY REAR TANK IS SUPPLIED.
 (B) 3WAY VALVE ON-OFF TAP OR 3WAY VALVE IF SEAT TANK OPTION IS FITTED DWG 99-00-301 OR 300

ALL FUEL LINE HOSE FIRE RESISTANT TYPE B-4
 REPLACEMENT FROM MAINAIR SPORTS ONLY

SAIL TENSION ADJUSTMENT HOLES

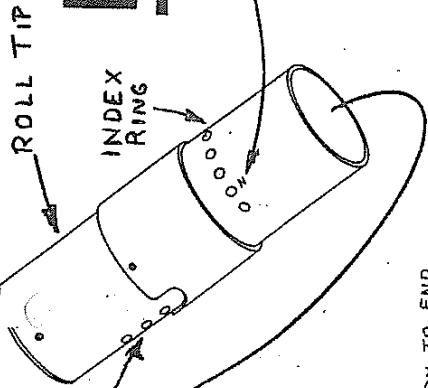

Flash One

NEUTRAL INDEX POSITION MARKED 'N'

ADJUST BY MOVING LINES UP OR DOWN ON CLEVIS PINS. LINES CAN BE IN ANY POSITION ON BARY PIN

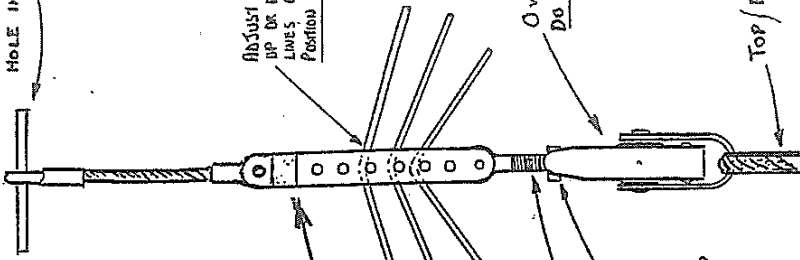

LEECH LINE ADJUSTER

NOTE :-
ENSURE THAT AT LEAST 5 FULL THREADS ENGAGED IN ADJUSTER

HOOK RIGGING TOOL ON TO END OF BATTEN, THEN LIFT RIGGING TOOL TO ENGAGE BATTEN CORD

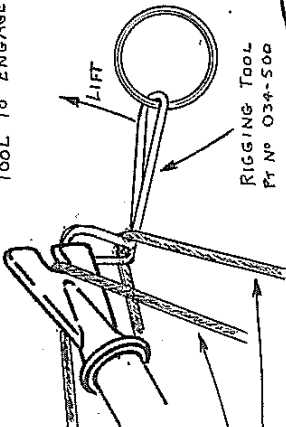

SHORT FLAT BATTENS ON LATER WINGS

MAIN BATTENS M

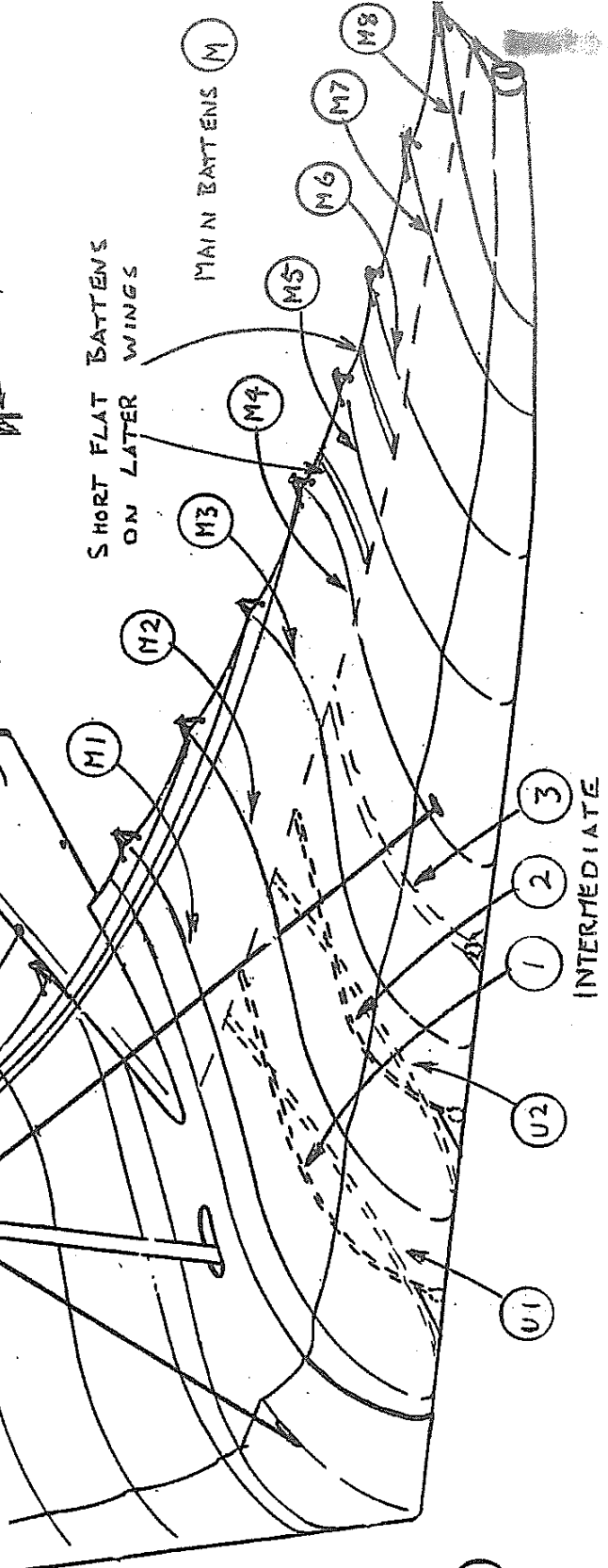

UNDER SURFACE BATTENS :- U

REF TO PAGE 14A

HANG POINT ADJUSTMENT

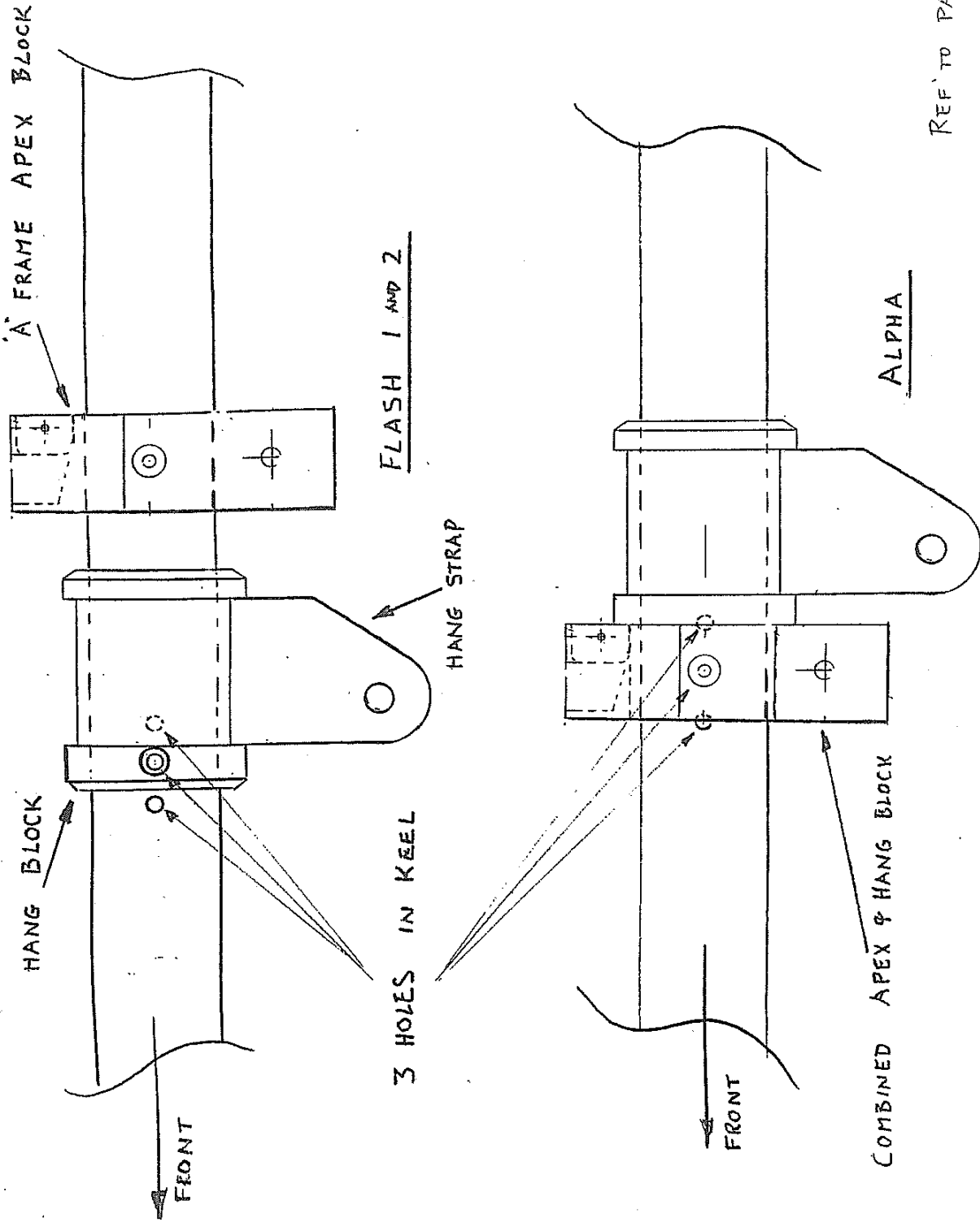

REF TO PAGE 14A

DWG No. FGA-75	
TITLE	FLASH DOWL NING DATE
LEECH LINE SETTINGS	10-5-84
REF	DATE
A	7-12-84
B	MAY 1985
C	APRIL 10 1986
D	MARCH 1987
E	SEPT 1990
AMENDMENT	
NOTE 4 APPENDED	
LEECH LINE DIMENSIONS CORRECTED TO ACTUAL ONES OBTAINED DURING PRODUCTION TEST FLYING.	
FLASH TWO DIMENSIONS ADDED	
FLASH 2 ALPHA ADDED	
FLASH 2 ALPHA DIMENSIONS DELETED SEE DWG N°FGA 76 FOR DETAILS	

FLASH 1

ADJUST BY MOVING LINES UP OR DOWN ON CLEVIS PINS. LINES CAN BE IN ANY POSITION ON ANY PIN

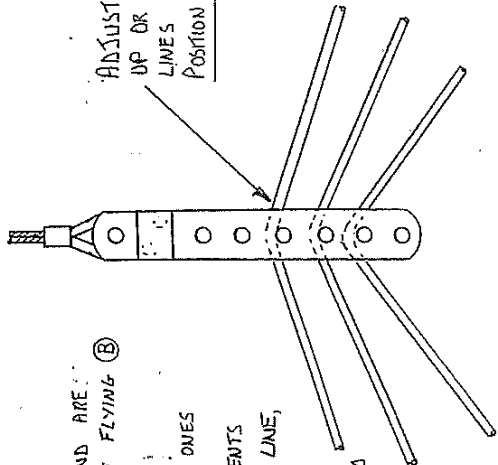

NOTES ON ADJUSTMENT

- ① THE DIMENSIONS SHOWN ARE APPROXIMATE AND ARE ESTABLISHED DURING FACTORY OR AGENT TEST FLYING ②
- ② THE OUTER LINES HAVE MORE EFFECT ON ROLL CONTROL & HANDLING THAN THE INNER ONES
- ③ AS THE WING "SOFTENS" WITH USE, ADJUSTMENTS MAY BE REQUIRED. ALWAYS ADJUST ONE LINE, ONE HOLE AT A TIME & FLIGHT TEST AFTER EVERY ADJUSTMENT
- ④ POSITIVE BAR PRESSURE MUST BE MAINTAINED AND THE AIRCRAFT TRIMMED OUT AT THE CORRECT AIR SPEEDS IN THE MANUAL

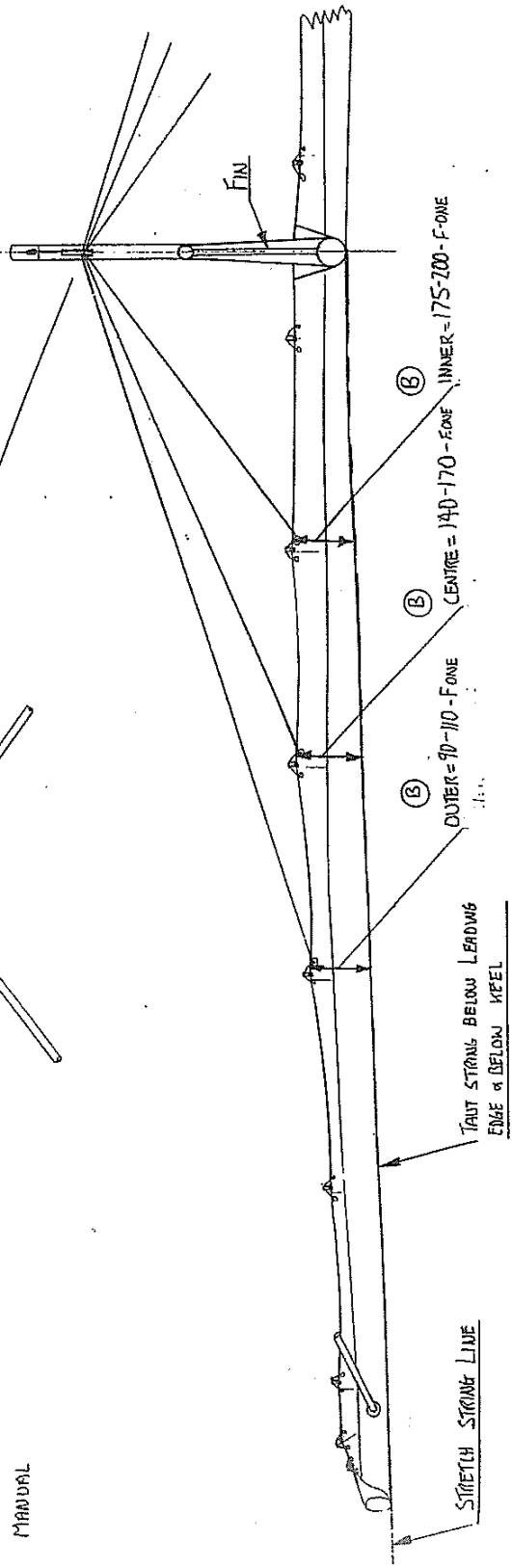

NOTE DIMENSIONS MUST BE SAME ON EACH WING AND MEASURED AT SAME TIME

VIEW FROM REAR